

THE VARIATION OF POWER OBTAINED BY SERIAL AND PARALLEL CONNECTION OF A SHOCK ABSORBER ENERGY RECOVERY SYSTEM INSTALLED ON A HYBRID HYDRAULIC VEHICLE

¹Vlad Șerbănescu *, Horia Abăitancei, Gheorghe-Alexandru Radu, Sebastian Radu

Transilvania University of Brasov

KEYWORDS – alternative propulsion, hydraulic hybrid, energy recovery, serial and parallel connection, one way valve.

ABSTRACT – The hydraulic hybrid system consists of four main components: the working fluid, reservoir, pump/motor (in parallel connected hybrid system) or in-wheel motors and pumps (in series connected hybrid system), and accumulator. In some systems, a hydraulic transformer is also installed for converting output flow at any pressure with a very low power loss. For further study the working developed power by the hydraulic installation of the hybrid hydraulic vehicle, two different premises were considered: serial and parallel connection of the recovery cylinders of the shock absorbers energy recovery system. To determine the optimum working parameters, numerical simulations were made using AMESIM software, by virtual modeling the recovery system. The main output working parameters are: the recovered driving speed, pressure in the hydraulic circuit, the flow and the effect on the damping process. As a general results, it can be observed, that the way how the shock absorbers are connected has a major influence on the performances of the recovery process. In order to get an answer to the problem of recovering shock absorbers connection type, series and parallel connection was analyzed. The optimum solution from the results of the simulations is considered the parallel connection of the recovery cylinders.

INTRODUCTION

To reduce CO₂ emissions, and to reach a sustainable stage, the transport industry actors have to think of new alternatives for the mobility issues. Cars produce up to 30% of the carbon gases in the earth atmosphere [1], which represents 76% of all carbon monoxide in the earth's atmosphere [1].

The on market solution are either to expensive, i.e. the electric car [2], unsafe, hydrogen fuel cells [3], and for other alternative fuels, like bio-diesel, the missing infrastructure is problematic.

A promising solution is the hydraulic hybrid propulsion system, demonstrated by the results presented by the Environmental Protection Agency in a joint research project with UPS and hydraulic component producers [1]. The results demonstrate up to 70% efficiency improvement in urban traffic considering brake energy recovery and more efficient running conditions for the internal combustion engine that allows downsizing of the engine and lower emissions [1]. So the advantage of hydraulic brake energy recovery is given by a relative cheap technology that is able de store up to 70% of the dissipated energy [4]. Shock absorber recovery was report in the USA by the University of Tuffts [5] using electrical principles and at MIT using hydraulic - electrical principles.

The studied system, discussed in this paper, consists of four main components: the working fluid, reservoir, pump/motor (in parallel connected hybrid system) or in-wheel motors and pumps (in series connected hybrid system), and accumulator. In some systems, a hydraulic transformer is also installed for converting output flow at any pressure with a very low power loss. Two different premises were considered: parallel (1) and serial (2) connection of the recovery cylinders of the shock absorbers energy recovery system. The objective of the research is to find the optimal connection solution for the recovery system.

EXPERIMENTAL DATA

To study the influences of the different connection methods on the outcome of the recovery system, two models were developed (Figure 1 and Figure 2). In Figure 1 is presented the parallel (1) connection manner for the dampers, and Figure 2 is showing the serial (2) connection.

The models used in the simulation of the energy recovery from the vehicle dampers are:

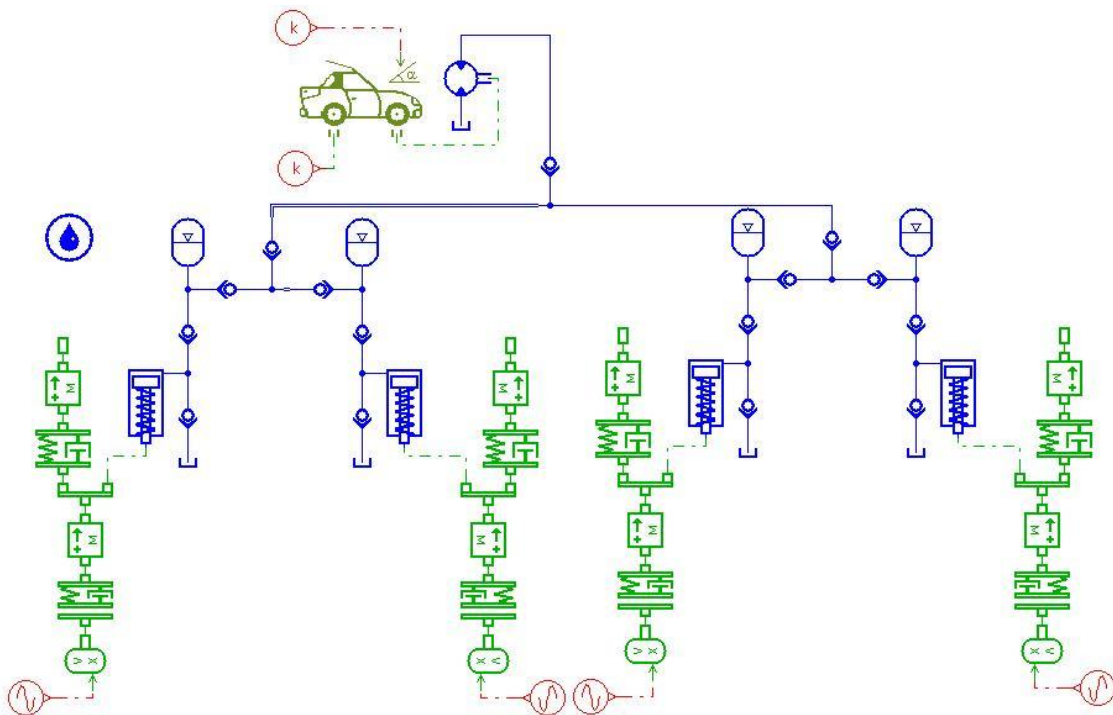

Figure 1: Model for four dampers connected in parallel.

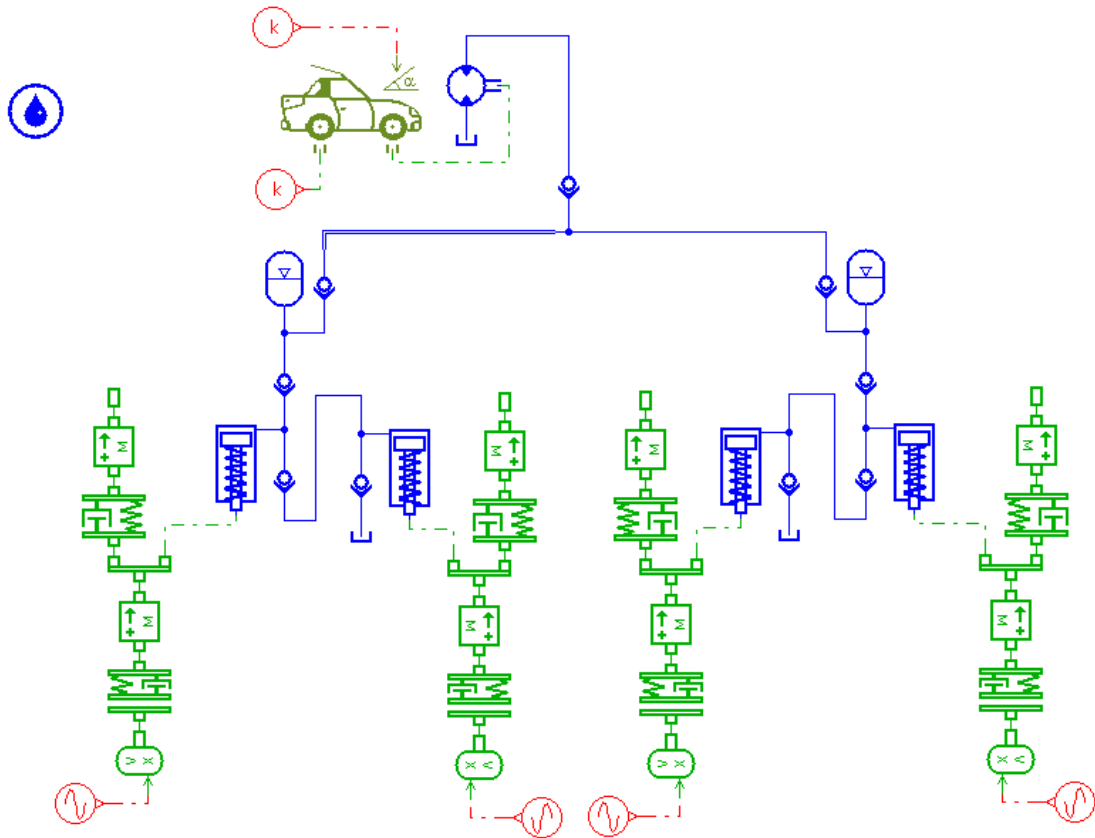

Figure 2: Model for four dampers serial connected.

Using the AMESim software [6], virtual simulations were made considering as input data, the values shown in Table 1.

Table 1: Input data

No.	Input data	UM	Value
1	Bumper frequency	Hz	30
2	Bumper height	m	0,005
3	Tire mass	kg	37
4	Tire damping degree	N/(m/s)	560
5	Vertical stiffness of tire	N/m	322 000 Bridgestone Turanza RFT [7] 874 000 Michelin Radial 11R22.5 XZA [7]
6	Spring Rate	N/m	39170
7	Damper Rating	N/(m/s)	2000
8	Mass of Vehicle	kg	400
9	Recuperative Piston Diameter	mm	45
10	Tank Pressure	bar	30
11	Gas Precharge Pressure	bar	100
12	Accumulator Volume	dm ³	7.5
13	Motor Displacement	cm ³ /rev	33
14	Vehicle frontal surface	m ²	3

RESULTS AND DISCUSSIONS

The numerical simulations were made with the help of the AMESim 8.0 software. These were made to evidence the best connection of the recovery cylinders which develops the biggest outcome power. Starting with Figure 3 it can be observed the difference between the serial and parallel connections of the recovery cylinders, when using two types of tires with different vertical stiffness values, 322000N/m for the Bridgestone Turanza RFT and 874000N/m for Michelin Radial 11R22.5 XZA tire. In the case when a set of tires with vertical stiffness of 874000N/m is used and the recovery cylinders are parallel connected we obtain a recovered speed of 41.6m/s instead of 34.2m/s when the cylinders are serial connected. Also it can be observed that for parallel connection of the recovery cylinders the speed is with 17.8% elder than serial connection of the recovery cylinders when we use Michelin Radial 11R22.5 XZA tire and when we use Bridgestone Turanza RFT tire, the speed obtain for parallel connection of recovery cylinders is with 30% higher.

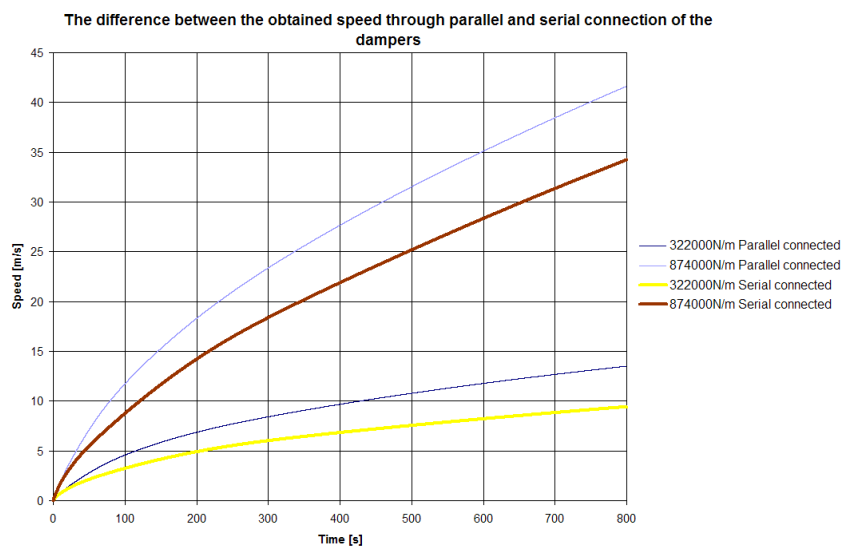

Figure 3: Speed of hybrid hydraulic vehicle

From Figure 4 it can be observed that for the same vertical stiffness of tire the pressure from the installation has a small fluctuation.

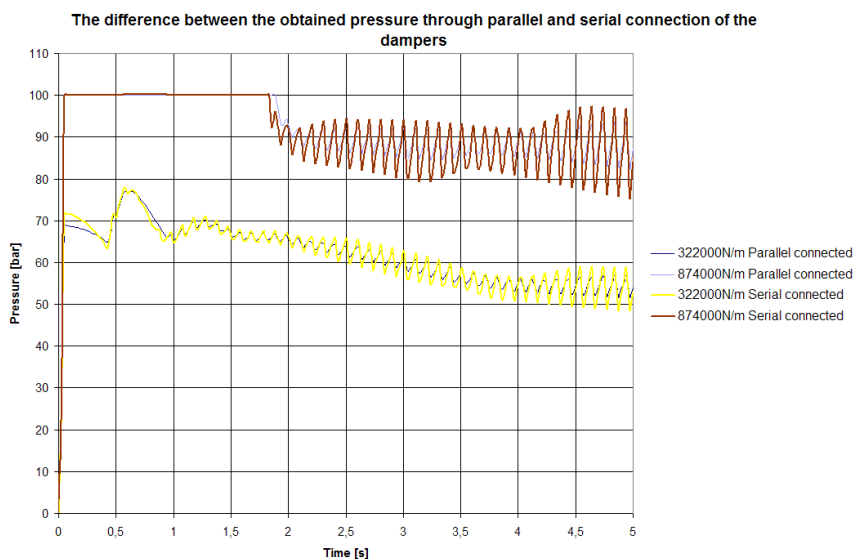

Figure 4: Pressure of hydrostatic motor

As it can be observed from Figure 5, the fluid flow in the recovery installation is directly proportional to the increase of the recovery speed, for a 41.6/s speed develop by parallel connection, the installation will debit 132.7L/m of hydraulic liquid for a vertical stiffness coefficient of 87400N/m. Compared with this value it can be seen that if rolled with a set of Bridgestone Turanza RFT tires with a vertical stiffness coefficient of 322000m/s the recovery speed will be only 13.5 m/s and the flow is only 43L/min.

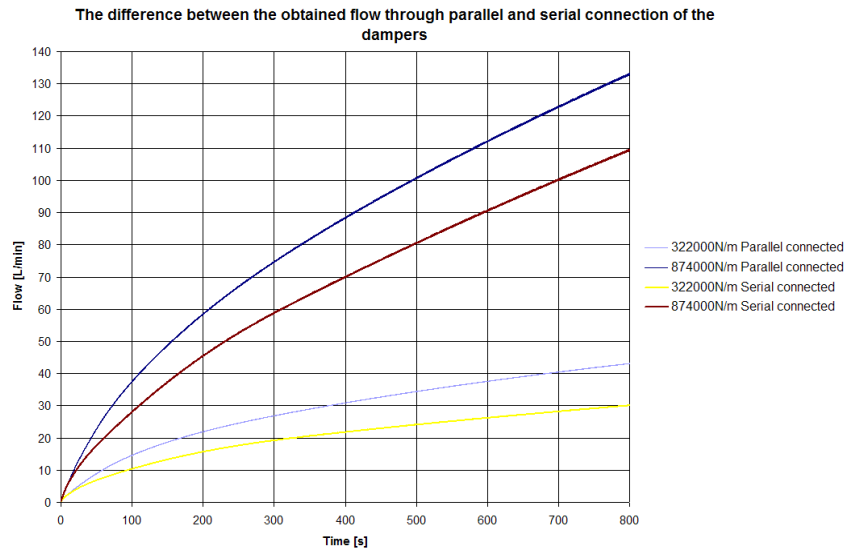

Figure 5: Flow of hydrostatic motor

The vertical displacement of the vehicle is influenced in small extend by the vertical stiffness coefficient of the tire because almost all the received energy from the road is picked up with the help of the recovery system and transformed in mechanical work. By connecting the recovery cylinders in series and parallel it was observed a $\pm 5\%$ oscillation of the vertical displacement of the car body, figure 6.

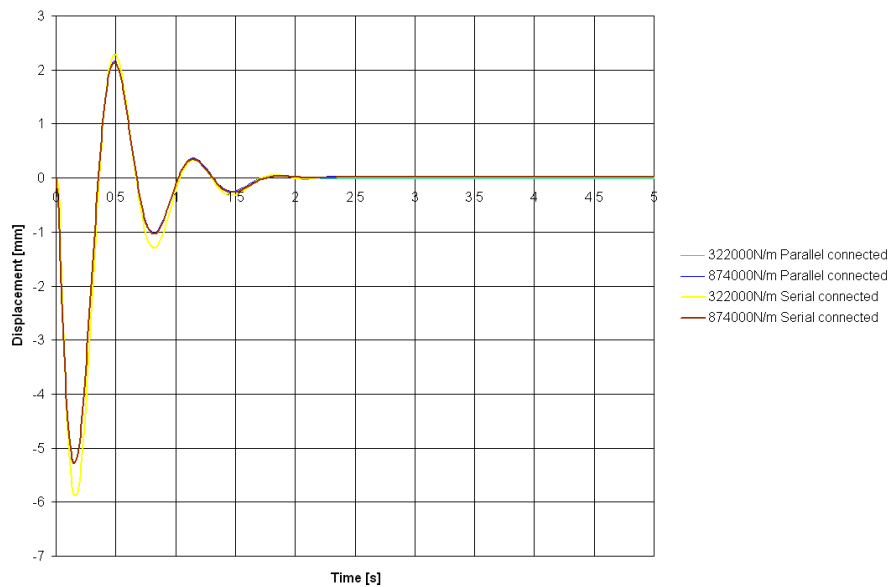

Figure 6: Vertical displacement of the vehicle

From Figure 7 it can be seen that the connection mode of the recovery cylinders and the vertical stiffness coefficient of the tire influence the recovery power. When using a tire with

874000N/m vertical stiffness and parallel connected cylinders the system generates 203.3kW, while by connecting in series the system develops 172.8kW and for tire Bridgestone Turanza RFT with 322 000N/m vertical stiffness, the recovered power for parallel connection is 40kW instead of 28.6kW for serial connection of recovery dampers.

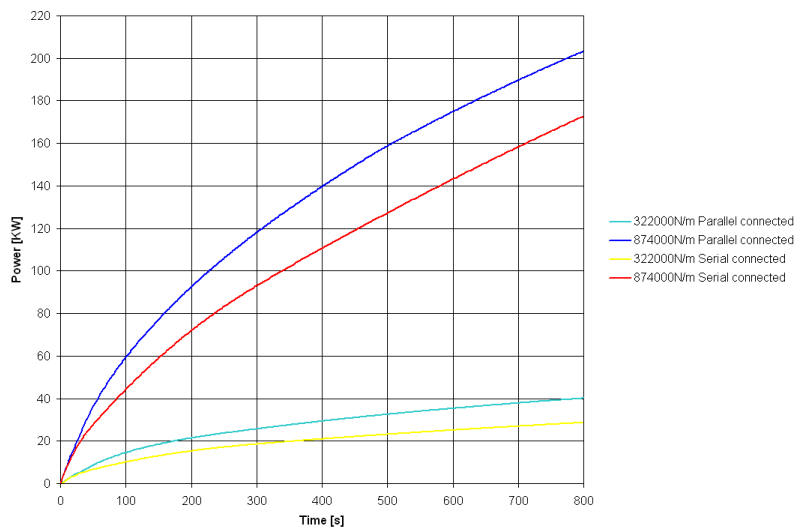

Figure 7: Power develop by energy recovery system

CONCLUSION

The system of energy recovery from vehicles dampers has demonstrated a high energetically capacity. Based on the simulations we can say that by using two tires with two different vertical stiffness coefficient it was observed that the rigid tire (874 000 Michelin Radial 11R22.5 XZA) recovers more energy from the road oscillation compare with Bridgestone Turanza RFT tire. This energy recovery system represents a step forward in the development of the hydraulic hybrid vehicle having the capacity of recovery big quantities of energy from the car dampers. Possible applications for the energy recovery system:

- Charging with propulsion energy of the vehicle which roll on difficult roads.
- Charging with hydraulic energy of auxiliary systems of special vehicles.
- Charging with energy of a system that converts the hydraulic energy in electrical energy.
- Stabilizing system of the heavy duty vehicles, ESP.

REFERENCES

- (1) www.epa.gov
- (2) <http://www.venturi.fr/electric-vehicules-astrolab-concept.html>
- (3) <http://www.alternative-energy-news.info/bmw-hydrogen-7-production/>
- (4) SAE Technical Paper, R. B. Goldner and P. Zerigian Tufts Univ, Dept of EECS “A Preliminary Study of Energy Recovery in Vehicles by Using Regenerative Magnetic Shock Absorbers” 2001.
- (5) SAE Technical Paper, R. B. Goldner and P. Zerigian Tufts Univ, Dept of EECS “A Preliminary Study of Energy Recovery in Vehicles by Using Regenerative Magnetic Shock Absorbers” 2001.
- (6) AMESim Rev 8B User Support 2008.
- (7) Hans B. Pacejka . “A Tyre and Vehicle Dynamics.” Linacre House, Oxford OX2 8D 2006