

ITERATIVE EXERGOECONOMIC OPTIMIZATION OF A COGENERATION SYSTEM

C. IONITA¹ M. MARINESCU¹
A. DOBROVICESCU¹ D. STANCIU¹

Abstract: The paper presents the exergoeconomic optimization of a simple cogeneration system composed of a gas turbine and a heat recovery generator. The iterative method for cost minimization is based on the exergy concept and the exergoeconomic variables.

Keywords: cogeneration, exergoeconomics, exergoeconomic variables

1. Introduction

The exergoeconomic optimization offers a coherent strategy, in continuous connection with the physical reality, for the search of the optimum solution. Besides the opportunity of finding the optimum solution, the exergoeconomic method also offers information about possibilities to continue the optimization procedure by the change of the system structure. The iterative technique of optimization requires minimum of available data (exergoeconomic variables) and offers information for the thermal systems optimization when other optimization procedures cannot be applied.

2. Exergoeconomic Variables

To identify the energetic efficiency and other variables is necessary to find out the *Product* (P) and the *Fuel* (F) for each analyzed thermodynamic system. The *Product* represents the net desired result produced in the system, and the *Fuel* represents the net resources which were

spent to generate the product. Both Product and Fuel are measured in exergetic units.

The variables considered in the exergoeconomic optimization procedure are ([1], [3]):

a) Exergetic efficiency of component k

$$\varepsilon_k = \frac{\dot{E}_{P,k}}{\dot{E}_{Cb,k}} = 1 - \frac{(\dot{E}_{D,k} + \dot{E}_{Pi,k})}{\dot{E}_{Cb,k}} \quad (1)$$

b) Exergy destruction rate $\dot{E}_{D,k}$ and exergy loss rate $\dot{E}_{Pi,k}$

The connection between Fuel, Product, Exergy destruction and Exergy loss in the k subsystem is given by the relationship:

$$\dot{E}_{P,k} = \dot{E}_{Cb,k} + \dot{E}_{D,k} + \dot{E}_{Pi,k} \quad (2)$$

c) Exergy destruction related to the fuel to the total plant

$$y_{D,k} = \frac{\dot{E}_{D,k}}{\dot{E}_{Cb,tot}} \quad (3)$$

d) Exergy loss related to the fuel to the total plant

$$y_{Pi,k} = \frac{\dot{E}_{Pi,k}}{\dot{E}_{Cb,tot}} \quad (4)$$

¹ Dept. of Thermodynamics, University Politehnica of Bucharest.

where $\dot{E}_{Cb,tot} = \dot{E}_{10}$ is the exergy rate of the fuel to the total system.

e) The amortization rate of the invested capital cost \dot{Z}_k^{CI} , and the associated cost to operating and maintenance \dot{Z}_k^{OM}

$$\dot{Z}_k = \dot{Z}_k^{OM} + \dot{Z}_k^{CI} \quad (5)$$

f) The associated cost to exergy destruction

$$\begin{aligned} \dot{C}_{D,k} &= c_{Cb,k} \cdot \dot{E}_{D,k} \\ \dot{C}_{D,k} &= c_{P,k} \cdot \dot{E}_{D,k} \end{aligned} \quad (6)$$

where $c_{Cb,k}$ is the unitary cost of the fuel exergy.

g) Relative cost difference:

$$r_k = \frac{1 - \eta_{ex} + \frac{\dot{Z}_k^{CI} + \dot{Z}_k^{OM}}{c_{Cb,k} \dot{E}_{P,k}}}{\eta_{ex}} \quad (7)$$

h) The exergoeconomic factor:

$$f_k = \frac{\dot{Z}_k}{\dot{Z}_k + \dot{C}_{D,k}} \quad (8)$$

3 Exergoeconomic Analysis - A Case Study

To show the special investigation and optimization abilities of the exergoeconomic analysis the scheme of a gas turbine system with air preheater and heat recovery generator has been chosen (fig.1). For such a system exergoeconomic correlations for the acquisition cost of the equipment are available. The two products are: the effective **Power** of the system $P_e=65$ MW and the **Saturated steam** 30 kg/s at pressure 20 bars.

The study of this cogeneration system accounts for the variation of the specific heat capacities with temperature and for

the change in the composition of the thermal agent after combustion.

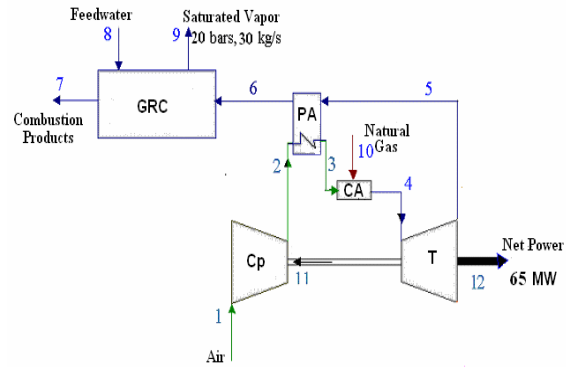

Fig.1. Structure of the cogeneration system

The objective function to be minimized is represented by the total cost of the product, cost composed by sum between the fuel rate cost and the capital investment amortization cost.

$$\dot{C}_T = \dot{C}_{cb} + \sum_{i=1}^5 \dot{Z}_k \quad (9)$$

In the analysis of the considered system, five operating zones have been distinguished: *compressor, combustion chamber, turbine, air preheater* and the *heat recovery steam generator* (table 1).

To determine the unknown costs (per unit of exergy) auxiliary relationships are necessary. The construction of such relationships is based on two principles: principle F and P.

Principle F: If in a subsystem the fuel is represented as the difference between an incoming flux of exergy and an outgoing one the cost per unit of exergy corresponding to these fluxes remain constant.

Principle P: If a system or subsystem has several outgoing fluxes (products) simultaneously obtained, their unitary exergetic cost is the same.

4. Evaluation – thermoeconomic optimization

The direction of the optimum search is given by the values and evolution, from the optimization procedure, of the exergy zone destruction costs, of zone capital

amortization costs, of zone exergetic efficiencies and of exergoeconomic costs. Based on the evolution of these parameters decisions will be taken regarding the sense and value of the change in the decisional parameters.

Fuels and Products for each subsystem of the considered plant

Table 1

Subsystem	Product	Fuel
CA	$\dot{E}_4 - \dot{E}_3$	\dot{E}_{10}
TG	P_T	$\dot{E}_4 - \dot{E}_5$
Cp	$\dot{E}_2 - \dot{E}_1$	P_C
GRC	$\dot{E}_9 - \dot{E}_8$	$\dot{E}_6 - \dot{E}_7$
PA	$\dot{E}_3 - \dot{E}_2$	$\dot{E}_5 - \dot{E}_6$

Mass flow rates, temperature, pressure, exergy rate and costs for cogeneration system energy fluxes

Table 2

Cost of the global system product: $C = 1,356$ Eu/s

State	Flux	Mass flow rate [kg/s]	Temperature T [K]	Pressure p [bar]	Exergy flux \dot{E} [MW]	Cost rate \dot{C}_i [Eu/h]	Exergetic unitary cost c_i [Eu/GJ]
1	Air	209,5	300	0,9648	0	0	0
2	Air	209,5	607,2	9,648	62,739	3327	14,73
3	Air	209,5	850	9,188	95,297	4587	13,37
4	Combustion products	213,3	1520	8,729	260,651	7368	7,852
5	Combustion products	213,3	1019	1,122	120,296	3401	7,852
6	Combustion products	213,3	793	1,089	81,017	2290	7,852
7	Combustion products	213,3	456	1,013	38,183	1079	7,852
8	water	30	300	20	0,132	0	0
9	Saturated steam	30	485,6	20	27,160	1465	14,99
10	Methane	3,763	300	12	226,362	2710	3,326
11	Thermal power	-	-	-	68,677	2467	9,979
12	Pe [kW]	-	-	-	65,000	2335	9,979

Values for the acquisition costs for the equipment and the thermoeconomic variables for the basic design case

Table 3

$$T_4 = 1520K, T_3 = 850K, \frac{P_2}{P_1} = 10, \eta_{SC} = \eta_{ST} = 0,86$$

Subsystem	PEC (10 ⁶ \$)	\mathcal{E} [%]	\dot{E}_D [MW]	y_D [%]	c_{Cb} [Eu/GJ]	c_P [Eu/GJ]	\dot{C}_D [Eu/h]	\dot{Z} [Eu/h]	$\dot{C}_D + \dot{Z}$ [Eu/h]	r [%]	f [%]
CA	0,707	81,03	61	26,95	6,308	7,852	1384	71,09	1455	24,61	4,886
TG	8,308	95,05	7,919	3,498	7,852	9,979	223,9	834,6	1058	27,08	78,85
Cp	8,56	91,35	5,939	2,624	9,979	14,73	213,3	860,3	1074	47,64	80,13
GRC	2,53	63,1	15,806	6,983	7,852	14,99	446,8	254,6	701,4	90,87	36,3
PA	1,482	82,89	5,757	2,542	7,852	10,74	162,7	148,8	311,5	36,81	47,78

The methodology presented in this paper can be used in an exploratory approach and its aim is to minimize the cost of the considered system [1].

First iteration:

$$\frac{P_2}{P_1} = 10, \eta_{SC} = \eta_{ST} = 0,86, T_3 = 850K,$$

$$T_4 = 1520K$$

(table 2)

1. Components are set in the decreasing order of the importance of their cost calculated as $\dot{Z}_k + \dot{C}_{D,k}$ (table 3)
2. Design changes for components with large values for this sum are considered.
3. A peculiar attention is turned to components with a large relative exergetic cost difference r_k (eq. 6), especially when \dot{Z}_k and $\dot{C}_{D,k}$ are large.
4. The exergoeconomic factor f_k (eq. 7) is used to identify the major source of cost (investment or exergy destruction cost).

By applying the presented stages one observes the following (figure 2): the combustion chamber, the turbine and the compressor have the largest values for the sum $\dot{Z}_k + \dot{C}_{D,k}$; they are the most important components from the thermodynamic point of view.

Combustion chamber (CA) has a low value for the variable f (figure 3) which shows that the values for the associated

costs are due near exclusively to the exergy destruction. Temperature T_4 is a key design variable, that influences the efficiency of the whole system and the investment costs of components.

Temperature T_3 is also a decisional variable because besides the combustion chamber it affects the exergy loss with current 7 as well as the performance and the investment cost of the air preheater and GRC.

An increase in these variables (T_3 and T_4) reduce the value of \dot{C}_D for the combustion chamber and other components, but increases their investment capital cost (figures 12, 13, 14, 15).

For the **gas turbine (TG)**, the relative large value for factor f (figure 2) suggests that, the capital investment cost and the maintenance and operating cost are dominant. The capital investment cost of the turbine depends on temperature T_4 , $\frac{P_2}{P_1}$ and η_{ST} . To reduce the high value \dot{Z}_t , one should reduce at least one of these variables (figures 10, 12, 14)

The compressor has the largest value f and the second as measure r in the plant (figures 3 and 4). It is expected an improvement of the whole system cost if the value \dot{Z}_{Cp} is reduced. That could be

obtained by reducing the ratio $\frac{P_2}{P_1}$ and η_{SC} (figures 6 and 8).

The Heat recovery generator (GRC) has the lowest exergetic efficiency and the largest value for r compared to other components (figures 4 and 5). The exergy destruction in the GRC may be reduced by the decrease in temperatures T_6 and T_7 . Temperatures T_6 and T_7 could be reduced by the increase in T_3 and/or by reducing T_4 when keeping constant the remaining decisional variables (figures 13, 15).

The air preheater (PA) having a relative high value for f suggests to reduce the investment cost of this component. That can be achieved by reducing T_3 (figure 14).

As a sum of the previous conclusions, the following changes in the decision variables are expected to reduce the system cost.

Thus, in taking a decision for modifying in a specific sense the values of ones of the decisional parameters, the dynamics of variation of the exergy destruction costs and of the investment amortization costs have been considered.

The above may be better observed if one presents the results of the sensibility studies of the zone exergy destruction and rate of amortization investment costs (see figures 6-14).

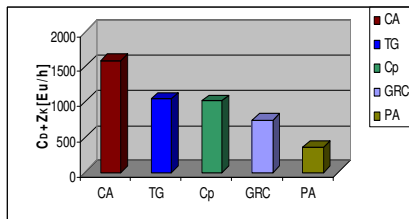

Fig.2. Graphical representation of the sum between the exergy destruction cost and the capital amortization cost for each component

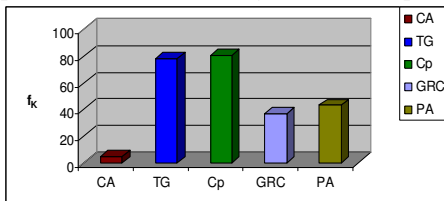

Fig.3. Graphical representation of the exergoeconomic factor f for each component

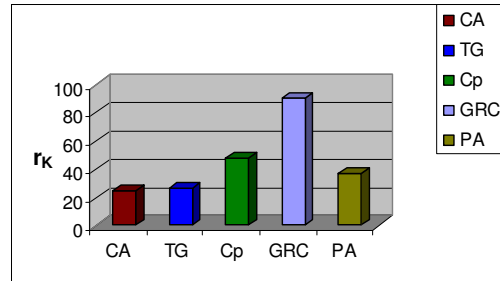

Fig. 4. Graphical representation of the relative cost difference r for each component

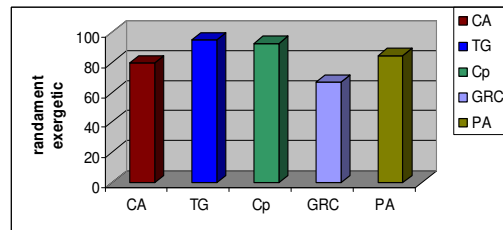

Fig.5. Graphical representation of the exergetic efficiency for each component

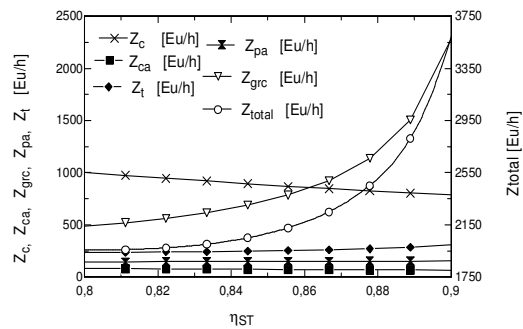

Fig. 6. Capital amortization cost at the variation of the compression ratio ($T_3=850\text{ K}$, $T_4=1520\text{ K}$, $\eta_{SC}=\eta_{ST}=0,86$)

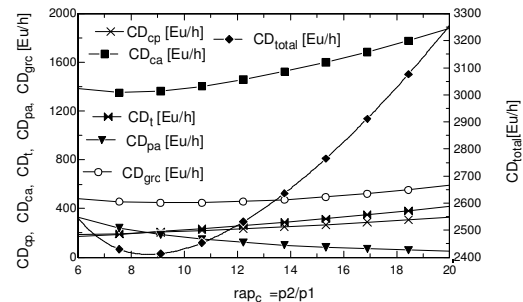

Fig. 7. Exergy destruction cost at the variation of the compression ratio ($T_3=850\text{ K}$, $T_4=1520\text{ K}$, $\eta_{SC}=\eta_{ST}=0,86$)

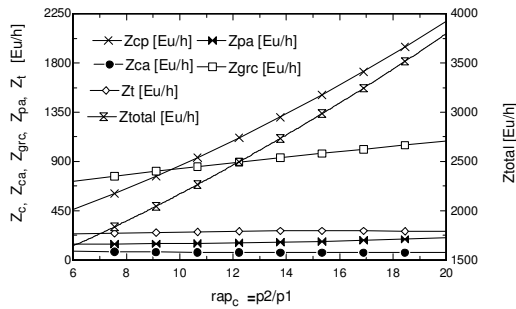

Fig. 8. Capital amortization cost at the variation of the isentropic efficiencies of compressor ($T_3=850\text{ K}$, $T_4=1520\text{ K}$, $\eta_{ST}=0,86$, $rap_c=10$)

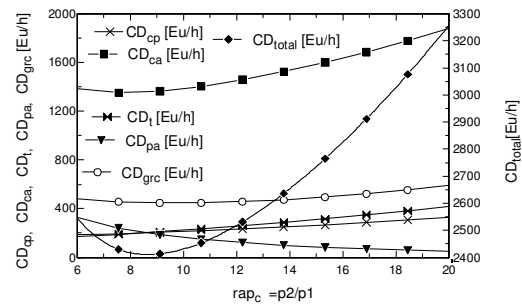

Fig. 9. Exergy destruction cost at the variation of the isentropic efficiencies of compressor ($T_3=850\text{ K}$, $T_4=1520\text{ K}$, $\eta_{ST}=0,86$, $rap_c=10$)

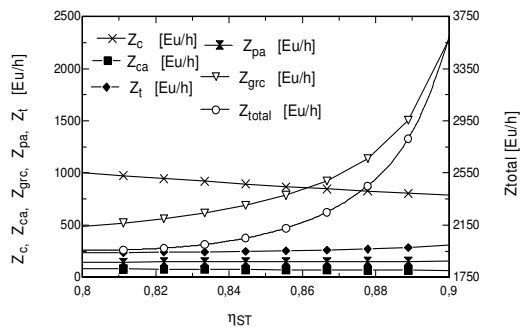

Fig. 10. Capital amortization cost at the variation of the isentropic efficiencies of turbine ($T_3=850\text{ K}$, $T_4=1520\text{ K}$, $\eta_{SC}=0,86$, $rap_c=10$)

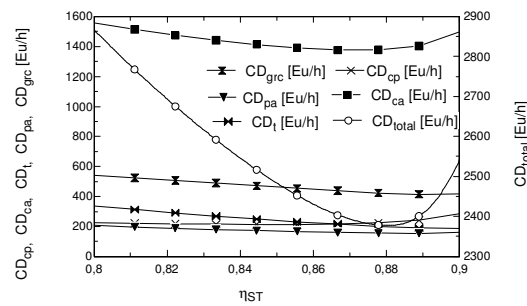

Fig. 11. Exergy destruction cost at the variation of the isentropic efficiencies of turbine ($T_3=850\text{ K}$, $T_4=1520\text{ K}$, $\eta_{SC}=0,86$, $rap_c=10$)

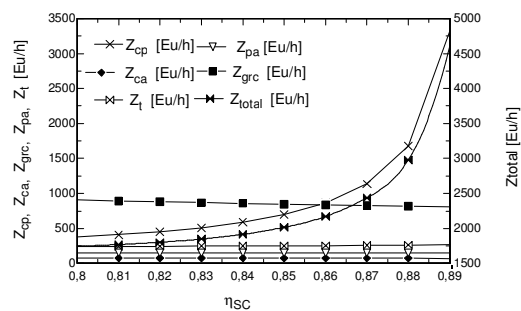

Fig. 12. Capital amortization cost at the variation of the temperature T_4 ($T_3=850\text{ K}$, $\eta_{SC}=\eta_{ST}=0,86$, $rap_c=10$)

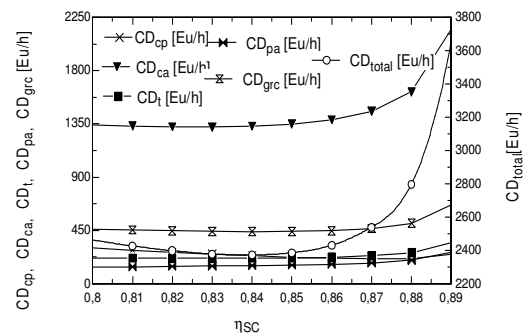

Fig. 13. Exergy destruction cost at the variation of the temperature T_4 ($T_3=850\text{ K}$, $\eta_{SC}=\eta_{ST}=0,86$, $rap_c=10$)

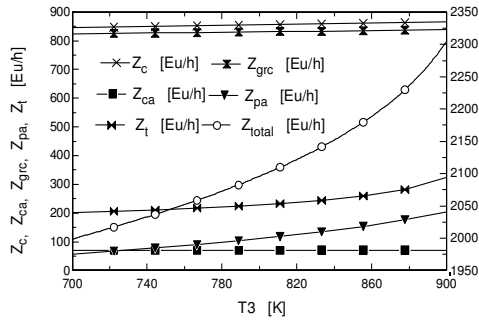

Fig. 14. Capital amortization cost at the variation of the temperature T_3 ($T_4=1520\text{ K}$, $\eta_{SC}=\eta_{ST}=0,86$, $rap_c=10$)

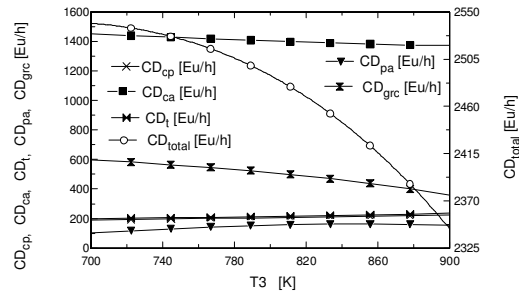

Fig. 15. Exergy destruction cost at the variation of the temperature T_3 ($T_4=1520\text{ K}$, $\eta_{SC}=\eta_{ST}=0,86$, $rap_c=10$)

Second iteration: The results of the exergoeconomic analysis corresponding to the second iteration from the optimum searching procedure are presented in table 4. Following the same way of reasoning the following changes in the decisional variables are proposed: the increase in temperature T_3

suggested by the evaluation of CA and GRC; the decrease in $\frac{P_2}{P_1}$, η_{SC} and η_{ST} from the evaluation evaluarea of Cp and TG; the decrease in T_4 suggested by the evaluation of TG and GRC.

Values of the equipment acquisition costs and of the thermoeconomic variables Tabel 4. for the decisional variables $\frac{P_2}{P_1} = 9$, $\eta_{SC} = \eta_{ST} = 0,85$, $T_3 = 870\text{ K}$, $T_4 = 1520\text{ K}$

Subsystem	PEC (10 ⁶ \$)	ϵ [%]	\dot{E}_D [MW]	y_D [%]	c_F [Eu/h]	c_P [Eu/G]	\dot{C}_D [Eu/h]	\dot{Z} [Eu/h]	$\dot{C}_D + \dot{Z}$ [Eu/h]	r [%]	f [%]
CC	0,74	81,24	62,837	27	5,92	7,364	1339	75,27	1415	24,39	5,321
TG	7,149	94,79	8,390	3,6	7,364	9,241	222,2	718,2	940,4	25,48	76,38
Cp	6,23	90,57	6,517	2,8	9,241	12,98	216,8	625,9	842,7	40,47	74,27
GRC	2,552	62,61	7,061	6,934	7,364	14,33	427,9	256,3	684,2	94,53	37,46
PA	1,62	83,04	16,140	3,034	7,364	10,01	187,2	163	350,2	35,96	46,54

The cost of the product of the global system: $C = 1,285\text{ Eu/s}$.

Additional iteration are necessary to get closer to the optimum solution. The values of the decisional variables that lead to optimum cost values are:

$$\frac{P_2}{P_1} = 7,443, \eta_{sc} = 0,8254, \eta_{ST} = 0,8648,$$

$$T_3 = 864K, T_4 = 1470K$$

With these values the value of the objective function becomes

$\dot{C}_{P,tot} = 1,173Eu/s$. The overall plant exergetic efficiency is over 38%.

5. Conclusions

The improve of the mathematical model has been done by achieving the exergoeconomic analysis of the plant as a whole and of each subsystem. This analysis gave the field of optimum decisional variables that correspond from both thermodynamic performances and cost with the acquisition and maintenance of the equipment.

An iterative method of cost minimization has been used which shows that exergy together with the exergoeconomic variables can be used for the minimization of the energetic system cost. After only a few iterations one reaches the optimum.

References

1. Bejan, A., Tsatsaronis, G., Moran, M.: *Thermal Design and Optimization*. New York. John Wiley & Sons, 1996.
2. Bejan, A., Mamut, E.: *Thermodynamic Optimization of Complex Energy Systems*, NATO Science Series, Kluwer Academic Publishers, 1999.
3. Dobrovicescu, Al., Stanciu, D. *Optimizarea exergoeconomică a unui sistem de turbină cu gaze*. In: COFRET 08, 11-12 iunie 2008, Nantes, France.
4. Tsatsaronis, G.: *Design optimization using exergoeconomics*.