

DEVELOPMENT OF A TESTING INSTALLATION FOR SHAPE-MEMORY-ALLOYS

¹Serban Radu, ² Paul Gumpel, ² Joachim Strittmatter

¹University Transilvania of Brasov, Romania ²Technical University of Konstanz, Germany

KEYWORDS - Shape Memory Alloys, Testing, Intelligent Materials, Peltier Effect

ABSTRACT - Recent development trends within the industry have revealed an increased interest in intelligent materials. They can offer the functions a shifter or an actuator do, but without using complicated electronics, an important issue with regard to the cost-reduction strategies of the past years.

Usually, shape-memory alloys are metallic materials in form of wires, plates or bars. They are characterized by the shape-memory effect which is a reversible thermo-elastic martensitic transformation with two thermal phases: the high-temperature phase (also called the austenitic-phase) and the low-temperature phase (also called martensitic phase).

In order to use shape-memory alloys in various applications the exact performances of the material has to be known. This is extremely important especially within the automotive industry where strict quality procedures and regulations are applied. It is maybe of interest to mention that an intended area of application is within the vehicle's safety systems.

In order to be able to deliver performance certificates for each tested sample, the Materials Department of the Technical University of Konstanz has managed to develop within the framework of a research project an installation dedicated for testing shape memory materials. The system is primarily designed to determine very precisely the temperatures of the two transformation phases under mechanical strain as well as to "train" the metal sample. The training (a cyclic thermal and mechanical load) induces in the material a certain shape-memory behavior.

The testing rig consists of a mechanical tensile strength machine, a thermal installation and a training installation. The most innovative part is the thermal installation which cools down and heats up the metallic samples by using the peltier-effect.

The developed testing rig can provide suppliers or manufacturers who intend to use intelligent materials in their products accurate data about the performances and quality of the shape memory alloys.

INTRODUCTION

Shape Memory Alloys (SMA) contain a very special set of properties. On one hand the physical characteristics of a metallic material, on the other hand the characteristics that can be trained, the so called system-properties. That is why the traditional material testing is not appropriate and not enough for SMA evaluation and a more dedicated method is needed to evaluate these materials. In the last decade, multiple SMA applications have been developed at the Technical University of Konstanz, whose direct implementation in the serial production fails because of missing testing procedures and devices. The purpose of this research study is to develop a universal test rig, able to provide valuable data about the properties of the tested

material. The acquired experience could also be the starting point of a standardized testing procedure.

Major difficulties for SMA applications are at the moment the differing properties of batches from the same material at delivery. This is caused mainly by a missing standardized testing procedure, able to provide the client with data about the system-properties of the purchased material. Because all SMA applications are exposed to mechanical loads, the transformation temperatures of the materials are increased, making an exact measuring quite difficult.

The main objective of this study is to develop and build a testing installation able to measure the transformation temperatures A_S , A_F , M_S , and M_F of SMA at the variation of following parameters: mechanical load, elongation and temperature. The testing rig should be able to test of SMA wires with different diameters, used by the laboratory of the Technical University of Konstanz in various applications. There is no such machine available on the market. The only measuring method used until now by the Laboratory in Konstanz was the Dilatometer. This device is limited because it enables only the measuring of small material samples. A further function of the testing rig is the “training” of the material. This is achieved by cyclic mechanical and thermal loads applied to the material.

SHAPE MEMORY ALLOYS

SMA are metallic materials able to “remember” their initial form after being exposed to a mechanical or thermal load. This is in fact a reversible thermo-elastic martensitic transformation. It is different from the normal martensitic transformation because of the formation of grouped plates with a different orientation which grow continuous with the decrease of temperature [1]. The causes of the reversibility are the small loads generated during the transformation which enable the accommodation of the martensitic plates in groups during the transformation phases. **Figure 1** shows the reversible austenitic to martensitic transformation which takes places at different temperatures forming a hysteresis [2], [3].

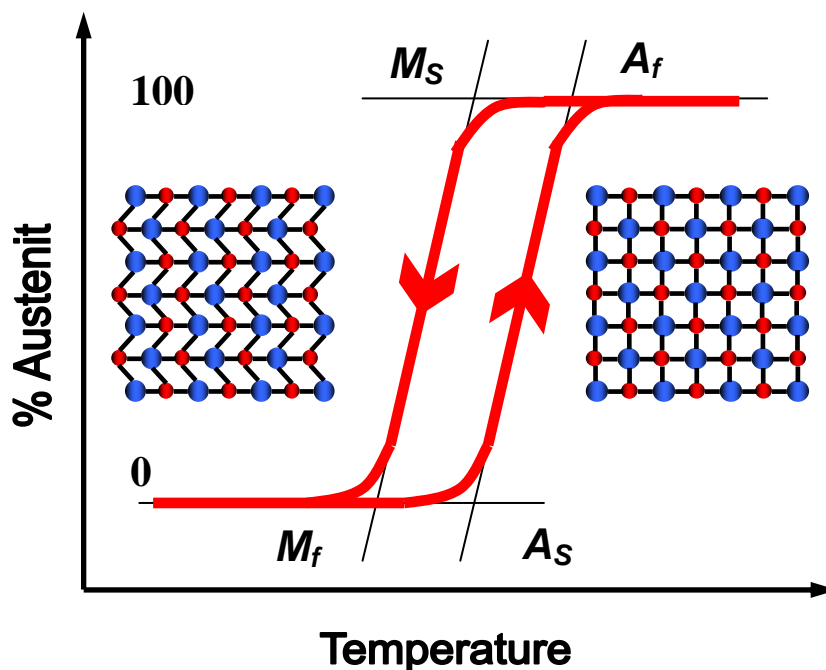

Figure 1 - The Austenitic-Martensitic Transformation

STRUCTURE OF THE TESTING RIG

The testing rig consists of three main parts: the tensile strength machine, the thermal installation and the training installation (see Figure 2).

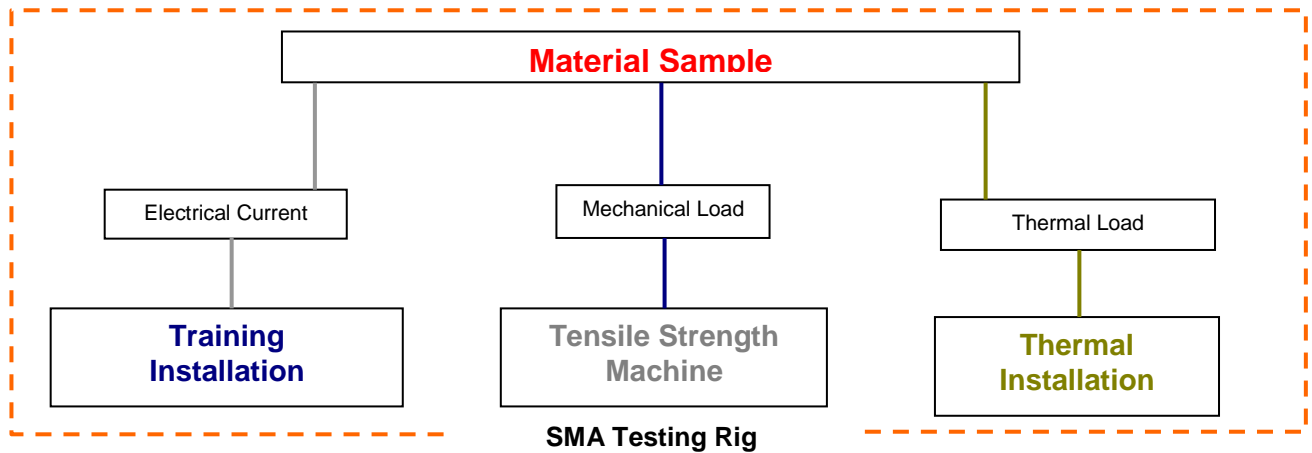

Figure 2 - Structure of the Testing Rig

A martensitic transformation is obtained by applying a certain force on the material sample. The elongation of the wire sample should be at least 4%. The role of the tensile strength machine is to elongate the sample to a certain percentage at a speed chosen by the test operator (due to the different diameters of the wire samples). All types of tests, whether establishing the transformation temperatures or material training, imply that the testing sample is under a controlled mechanical load. A universal tensile strength testing machine from Zwick GmbH, Germany was chosen. It can load the sample with a force up to 2.5kN. The testing machine was positioned horizontally in order to avoid the “chimney effect” of the thermal installation.

The thermal installation has to cool down and heat up the material sample. It is based on the Peltier effect and was designed with the help of the Peltron Company from Fürth, Germany. The electric current being forced through a junction of two different metals generates a calorific effect. By switching the direction of the current either heating or cooling is achieved [4]. The installation has five peltier-elements in a serial connection. It was designed like box with two halves that can be opened in order to have easy access to the material samples. The installation has a water-cooling circuit with a 15 liter tank and a 4 l/min pump. It works in a temperature domain of -50 to 200°C.

1. Peltier installation
2. Water tank
3. Temperature sensor
4. Water pump
5. Plug valve

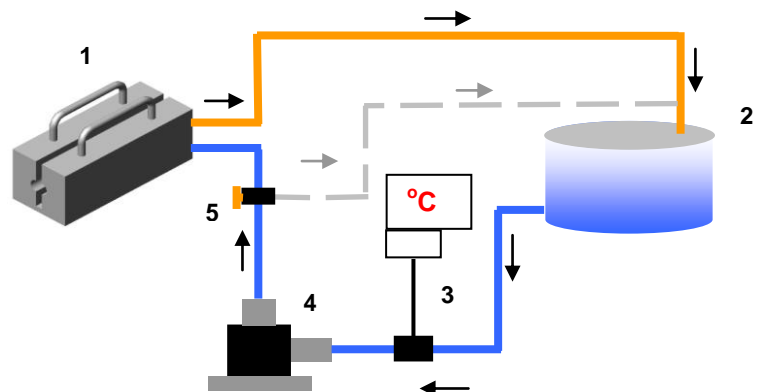

Figure 3 - The Pletier Thermal Installation

The thermal installation can also create cooling and heating cycles programmed by the testing operator.

The role of the training installation is to electrically charge in cycles the material sample with a controlled voltage and amperage. The current is provided by a power supply with controllable volt/ampere output. The opening and closing of the circuit is done by a relay controlled by a PLC module.

1. Tensile Strength Machine
2. Load Cell
3. Power Supply
4. Relay
5. PC with PLC Module

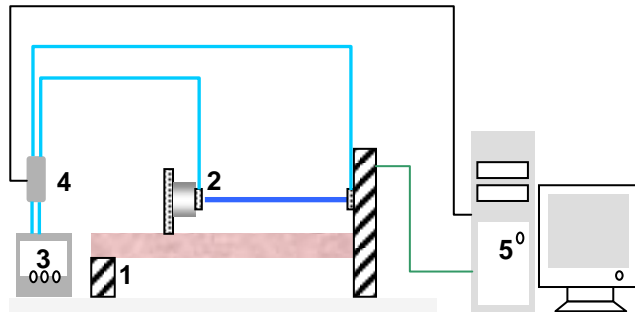

Figure 4 - The Training Installation

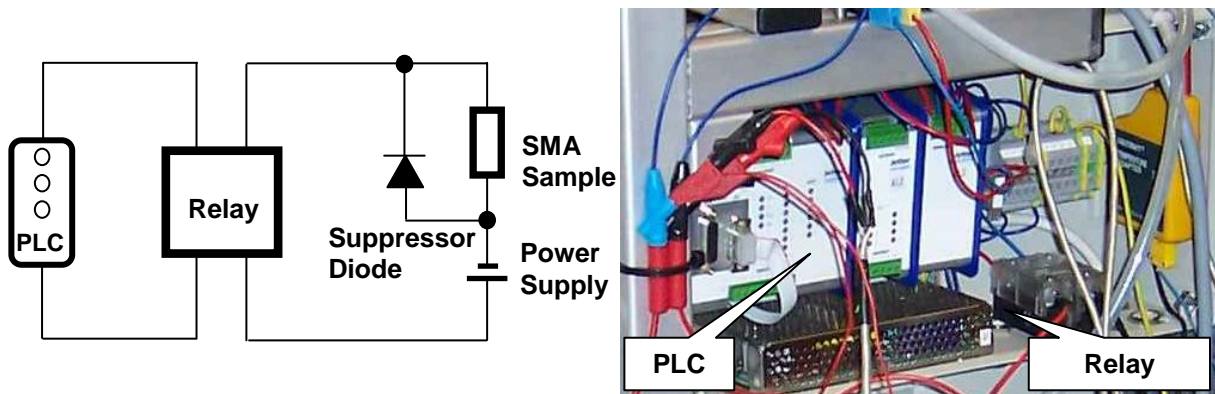

Figure 5 - Control System of the Electric Circuit

Special attention was given to the design of the sample fasteners. They have to fulfill multiple tasks. First they have to fix wire samples with different diameters to the tensile strength machine and to electrically isolate the samples from machine. Second, a low coefficient of thermal expansion is needed for fasteners, in order not influence the elongation measurements of the samples. The material used to build these parts is Invar, which has a linear coefficient of thermal expansion of about 1.7 to $2.0 \times 10^{-6} [K^{-1}]$. In order to accommodate the different wire diameters a series of steel plates with grooves has been designed.

1. Sample fastener
2. Sample fastener and tensile machine holder assembly
3. Sample fastener and steel plates assembly
4. Steel plates with grooves for the different wire diameters

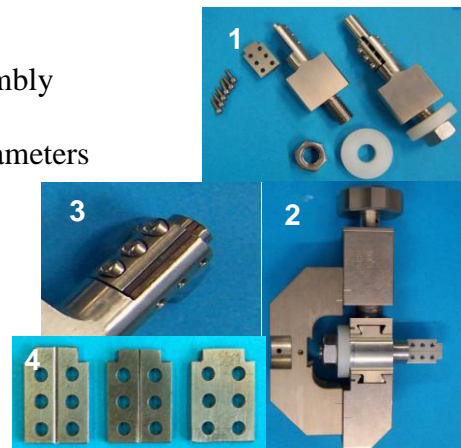

Figure 6 - Sample Fasteners

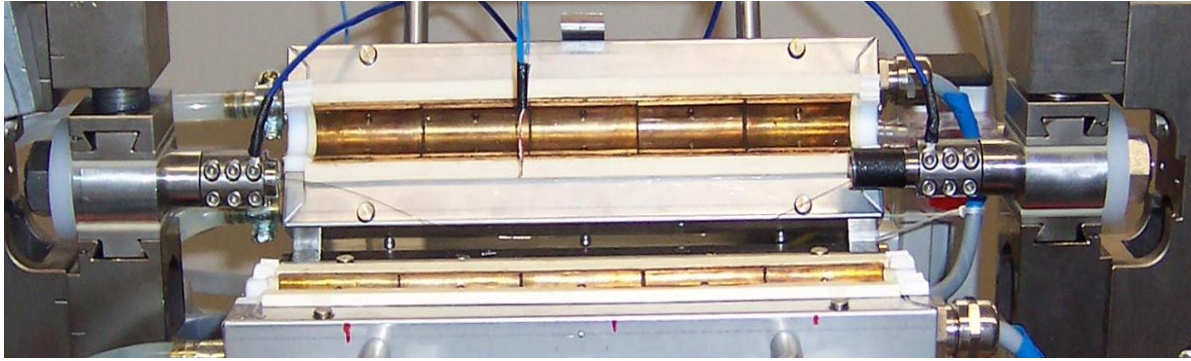

Figure 7 - Mounting of the SMA Wires into the Testing Machine

Figure 7 shows the way the SMA wires are mounted into the testing machine using the sample fasteners and the machine holders. The blue electric wires are used to apply the voltage on **the material** sample.

The complete testing rig, including the tensile strength machine with the training and thermal installations is pictured in Figure 8.

1. Thermal installation
2. Tensile strength machine
3. Control electronics
4. PC
5. Control unit of thermal installation
6. Power supply

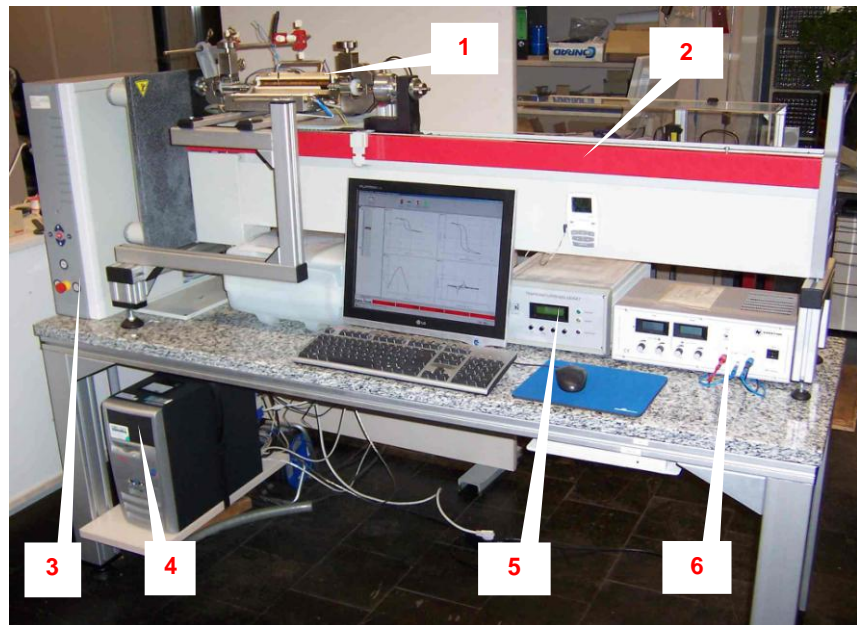

Figure 8 The Complete SMA Testing Installation

TESTING OF SMA SAMPLES

The Zwick Tensile Strength Machine is controlled by the TextExpert software (Zwick proprietary software). For the SMA testing the standard configuration of the software had to be modified. TextExpert enables the user to modify the program configuration and the desktop layout as well as to program scripts using the Zwick Zimt Script module. A new desktop layout was created, in order to display in real time the variation of the following parameters: sample elongation in mm vs. temperature, sample elongation in % vs. temperature, temperature vs. time and load vs. time.

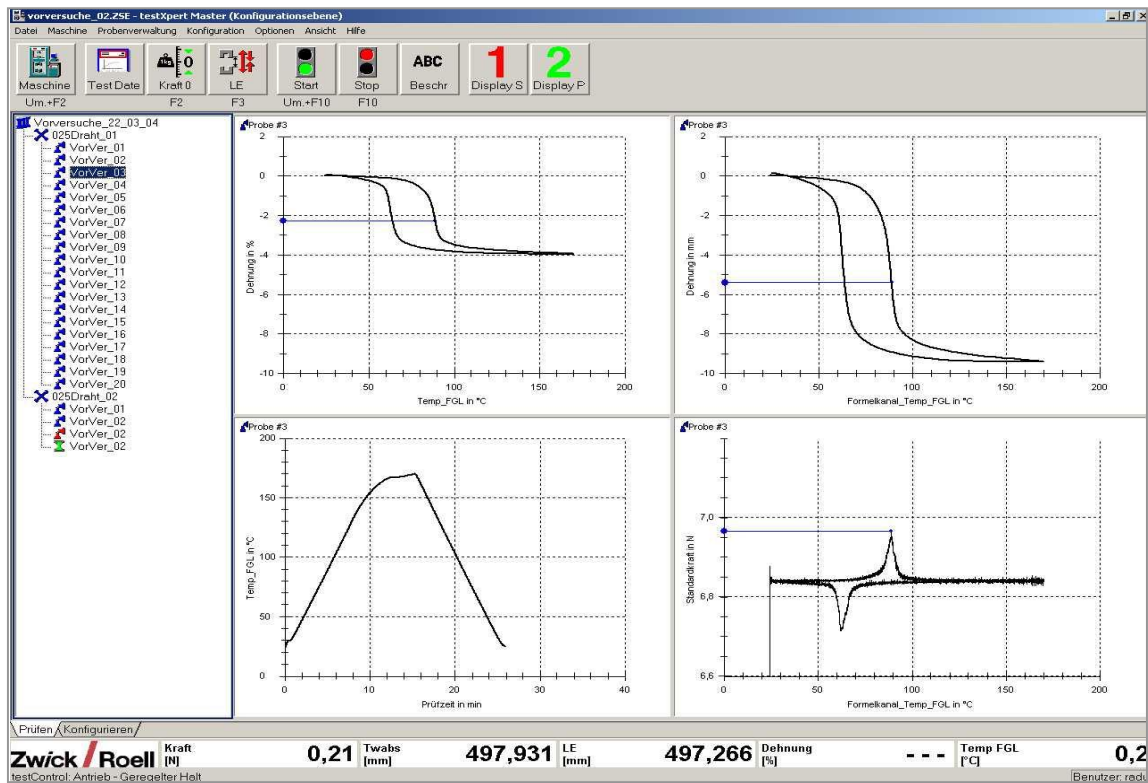

Figure 9 - TestExpert Desktop Layout

Test results of a SMA sample are shown in Figure 9. The tested Nickel-Titanium alloy has a memory effect of about 4% (according to the producer), a diameter of 0.245mm and a length of 290mm. After fixing the sample to the machine using the sample fasteners, the SMA wire is being preloaded with 0,1N in order to measure the exact length of the sample. The technician has to open the test program and to input the required test parameters. A separate procedure is needed for the thermal installation whose electronics are not integrated into the Zwick machine. For this test, a cycle has been programmed consisting in a heating of the sample from room temperature to 160°C in 500sec followed by cooling to room temperature in the same amount of time. The testing procedure can be then started from the TestExpert program. The tensile strength machine is applying on the wire a force of 135N/mm², chosen by the technician according to the manufacturer specifications or according to desired application of the SMA sample. After reaching this value, the machine enters in the “keep load” modus, meaning the load will remain constant regardless of the sample elongation and the temperature cycle can be started. The sample will be then heated and cooled under load, to measure the exact transformation temperatures. After reaching the room temperature (end temperature) the test procedure is ended automatically.

TRAINING OF SMA SAMPLES

The training procedure ensures a stabilization of the memory effect. The Zwick TestExpert software enables the technician to program the PLC to generate a complete profile of the voltage output. The analogue output of the PLC is connected to a relay that opens and closes the circuit accordingly (see Figure 5).

Following parameters can be programmed:

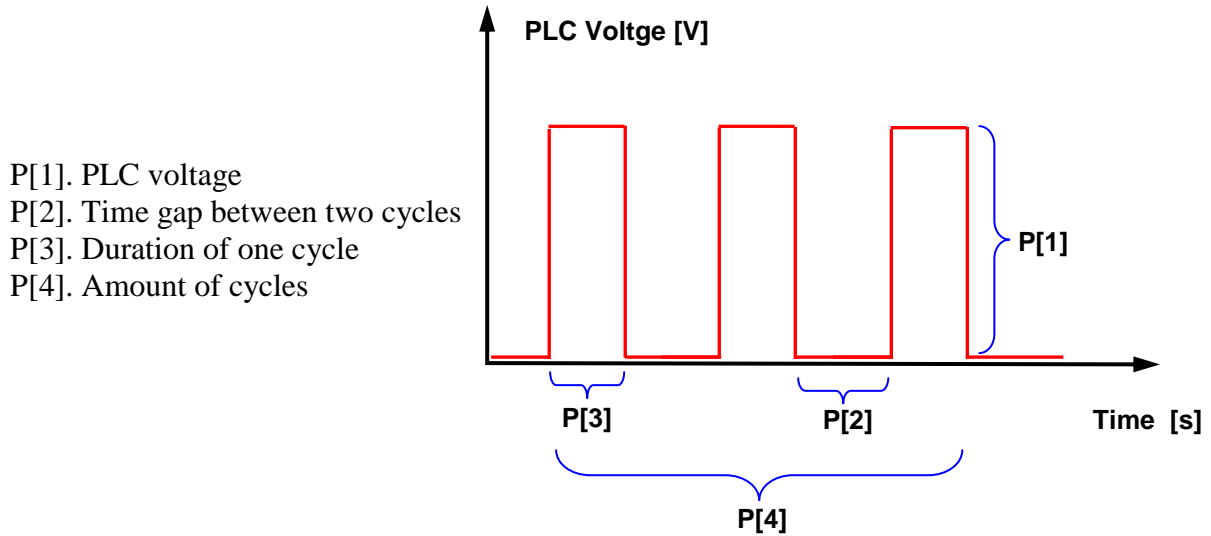

Figure 10 - Voltage output profile of the PLC

The SMA samples are fixed to the machine similar to the testing procedure. Two more wires (see Figure 7) are attached in order to connect the sample to the electric circuit of the training installation. The technician has to open the SMA-Training program from TestExpert and input the required test parameters. The sample will be then preloaded with a force required by the SMA type of application. Before starting the data acquisition, the power supply has to be setup for the test and switched on. After the programmed number of cycles is achieved the TestExpert ends the procedure automatically.

The training procedure test results of an SMA sample similar to the one described above are shown in Figure 11.

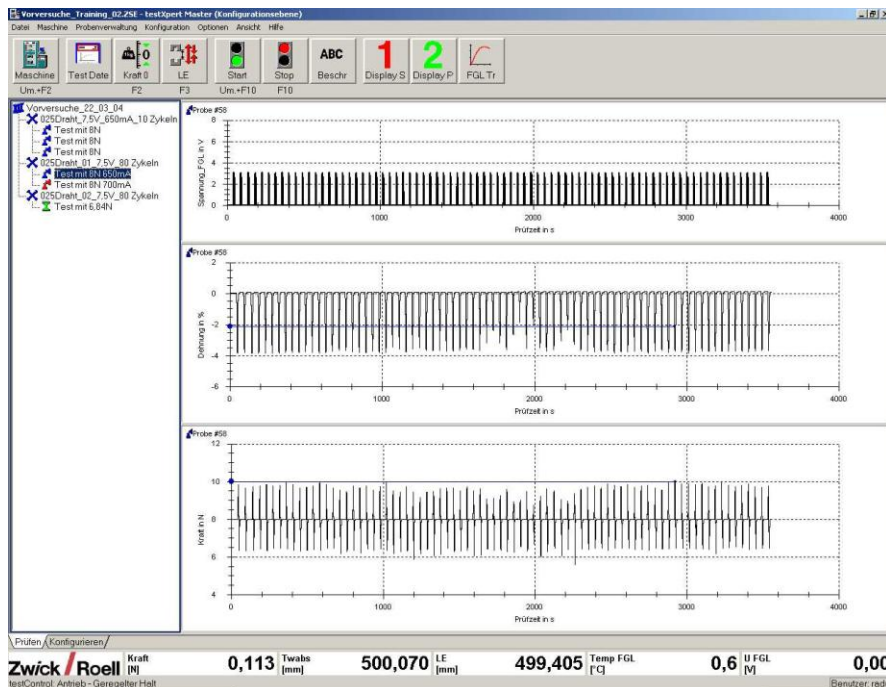

Figure 11 - Test Results of SMA Training Procedure

Following input parameters have been used for this test:

- Preload of the SMA sample: 8N
- Number of cycles: 80

- Time gap between cycles: 10sec.
- Duration of one cycle: 5sec.
- Amperage: 650mA;
- Voltage: 7,5V;

CONCLUSIONS

The goal of this project was to provide a testing unit to suppliers or manufacturers who intend to use intelligent materials in their products and need accurate data about the performances and quality of the shape memory alloys.

A possible future development step for the testing rig would be a complete integration of the control electronics in only one unit and a redesign of the thermal installation for an improved heating time.

ACKNOWLEDGEMENT

This paper is supported by the Sectoral Operational Programme Human Resources Development (SOP HRD), financed from the European Social Fund and by the Romanian Government under the contract number POSDRU/891.5/S59323.

REFERENCES

- [1] Seidel, Wolfgang : Werkstofftechnik; München, Wien; Hanser Verlag 1990.
- [2] Stöckel, Dieter : Legierungen mit Formgedächtnis; Band 259, Kontakt und Studium; Expert Verlag 1988.
- [3] Fischer, Falko : Literature Review of Different Influences on the Shape Memory Effect and Development of a Test Facility for Shape Memory Wires; Thesis Project; Escuela Superior de Ingenieros Universidad de Sevilla, Fachhochschule Konstanz; May 2000.
- [4] Kupsch, Wolfgang, J. : Anmerkungen zur Anwendung der Peltier Elemente; http://www.efindon.de/efindon/pdf/peltier_elemente-aufsatz.pdf.