

Development of a Seat Heating System with Far-Infrared Radiation

Mariana Ivănescu¹, Ionel Vieru¹, Cătălin Neacșu², Florin Șerban¹, and Ion Tabacu¹

¹ University of Pitești, Pitești, Romania, ² SC Automobile Dacia SA, Mioveni, Romania
{mariana.ivanescu, ionel.vieru, florin.serban, ion.tabacu}@upit.ro
catalin.neacsu@renault.com

Abstract. The thermal comfort sensation is assured by the factors that depend on the heat exchange between the human body and the ambient environment. This paper presents the development of a seat heating system for automotive with infrared radiation which offers an improved human thermal comfort. The proposed solution uses a heating kit that includes a few materials and the heat source is a radiant foil based on far-infrared radiant heat which gives a longer heating effect than other heating systems. In this paper will be analyzed the temperatures in different points on the automotive seat measured on the experimental way both for the heating system with infrared radiation, as well as the system using the electrical resistance, knowing that both systems develop the same power.

Keywords: seat heating system · infrared radiation · thermal comfort · automotive.

1 Introduction

The thermal comfort sensation is assured by the factors that depend on the heat exchange between the human body and the ambient environment.

This paper presents the development of a seat heating system for automotive with infrared radiation which offers an improved human thermal comfort. Most of the heating systems for the automotive seats use electrical resistance and the heat is transmitted to the human body only by conduction.

In relation to international state of the art there are a lot of researches concerning car seat heaters which use electric resistance, carbon fiber and infrared way for improvement of the thermal comfort.

Car heating systems integrated into the seat or in the passenger compartment have been the source of different brevets. The chosen solutions include the integration of a thin carbon fiber layer on the seat foam, powered by the vehicle battery [1] or integration of a resistive wire in the foam support [2]. Also in the DE102007039423 A1 [3] patent is presented a heating device for vehicle seat of motor vehicle, particularly open passenger car, has heating element, by which body area, particularly head, shoulder and neck area of seat passenger are heated.

To improve human thermal comfort inside the passenger compartment one other solution include an infrared heating device for warming upper body of e.g. driver or passenger car, has heat radiator arranged at rear side of mirror element of inner mirror i.e. inner rearview mirror, where mirror element comprises reflecting surface [4].

2 Development of Seat Infrared Heating

2.1 About the Infrared Heating

The proposed solution uses a heating kit that includes a few materials and the heat source is a radiant foil based on far-infrared radiant heat which gives a longer heating effect than other heating systems. The infrared radiant heat flux transferred to human body is transmitted by electromagnetic wave [5]. Far-infrared ray and anion are known to effectively suppress odors and growth of germs and boost the metabolism of the human body, not to mention the fact that they provide a healthier environment. The first advantage of the infrared heating system in comparison with classical system is the uniform heat flux transmitted to surface of the human body and the second advantage is that this solution offers different temperatures, especially in the lumbar area resulting a rapid achievement of the thermal comfort.

2.2 Integration of the IR Kits on Seats

The developed solution propose the use of heating kits which are placed on four areas of the seat (A, B, C, D areas), as seen in figure 1 [6,7].

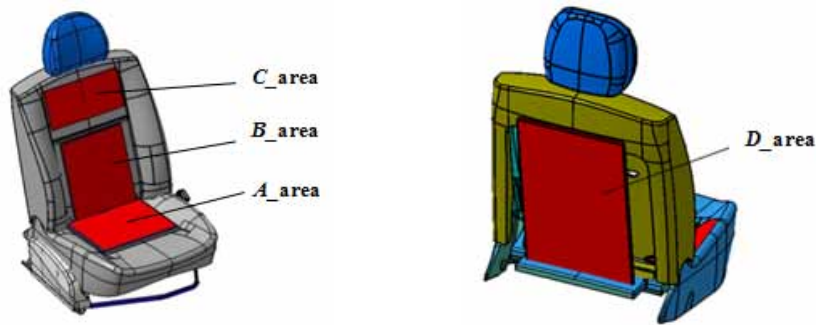

Fig. 1. Infrared kits placement on four areas of the seat

When using the classic seat heating system is difficult to obtain a optimal temperature for the rear passengers in a short time. By putting the heating kit in the D area, we obtain a increase in thermal confort for rear seat passengers.

To reduce the transmission of heat flux to the seat foam, the kits are composed from the following layers of material: honeycomb type textile material used as seat cover/ infrared foil/aluminum foil/ thermal insulating material (fig. 2).

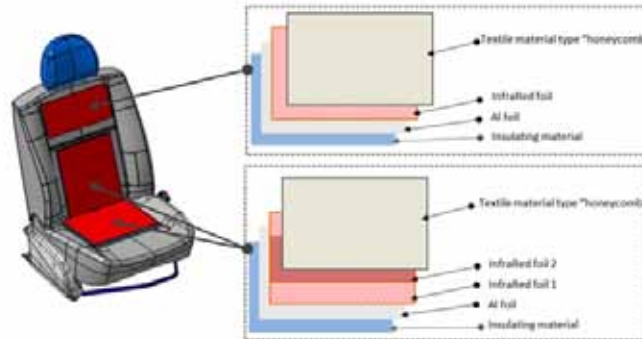

Fig. 2. Infrared kits placement and their components

To optimize the electrical energy consumption, the system is started/stopped manually, using two switches: one for A, B and C areas (called S_1), and the other for the D area, needed to increase the thermal comfort for the rear seat passengers (called S_2).

Also, to obtain an optimal thermal comfort and thermal protection of the system, both systems are equipped with thermostats: a 45°C thermostat with S_1, and for the S_2 a 50°C thermostat.

3 Experimental Results

In this paper the experimental researches and results were obtained in a laboratory environment and have completed two distinct stages. In the first part will be analyzed the temperature variation measured on the experimental way both for the heating system with infrared radiation, as well as the system using the electrical resistance and the heat flux is transmitted to environment. In the second part will be measured the temperatures values in different points on the automotive seat measured on the experimental way for the new heating system with far infrared radiation and the heat flux is transmitted to human body [6].

3.1 Experimental Setup

To be able to compare from experimental point of view the results obtained with both heating systems (electric resistance heater vs. infrared heater) we will develop an infrared foil heater that develop the same power as the electrical resistance heater.

In figures 3 and 4 are presented the placement of both systems to be able to visualize the heat flux transmission to the environment and the temperature variation in time.



Fig. 3. Electric resistance heater



Fig. 4. Infrared heater

The physical parameters for both systems (electrical current, voltage and system power) are presented in table 1.

Table 1. The physical parameters corresponding heating systems

Physical parameters:	Electrical resistance system	Infrared foil system	
		<i>S_1 system</i>	<i>S_2 system</i>
Electrical current [A]	5.8 A	5,8 A	5.9 A
Voltage [V]	14,5 V	14,5 V	14,5
System power [W]	84.1 W	84.1 W	85.5 W

To determine the infrared heating system performance we must measure the temperatures between seat cover and human body, such as the temperature value on the D_area surface. The data acquisition is realized with the NI DAQ - 9188XT system using K type thermocouples, placed on the seat cover as seen in figure 5.

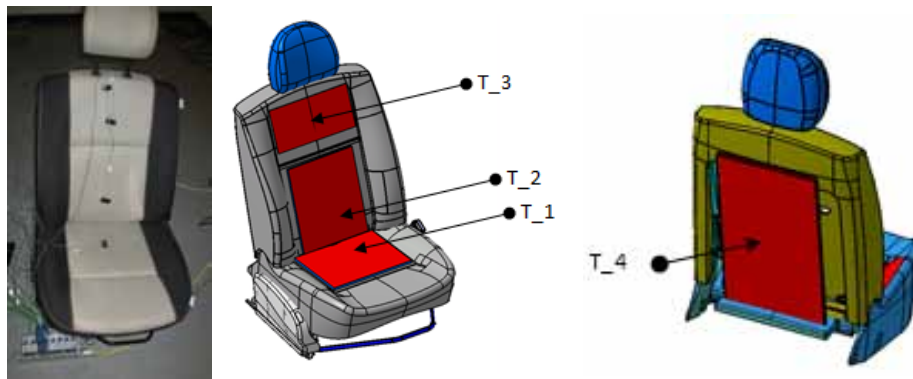

Fig. 5. Thermocouples placement on the seat cover

3.2 Results

The experimental results obtained by comparing heating system with infrared foil and electric resistance system are presented in table 2 and under graph form in figures 6 and 7 (T_{res} – the temperature of the electrical resistance system, T_{IR} foil - the temperature of the IR system, ΔT – temperature difference between the two systems).

Table 2. Table 2: Temperature values for the both heating system

Time[s]	T_{res} [°C]	ΔT_{res} [°C]	T_{foil_IR} [°C]	ΔT_{foil_IR} [°C]	ΔT [°C]
0	19.3	0	19.3	0	0
60	19.9	0.6	22.6	3.3	2.7
120	21.8	2.5	26.1	6.8	4.3
180	23.3	4.0	28.6	9.3	5.3
240	24.5	5.2	30.5	11.2	6.0
300	25.8	6.5	31.9	12.6	6.1
360	26.4	7.1	33.0	13.7	6.6
420	27.1	7.8	33.7	14.4	6.6
480	27.6	8.3	34.6	15.3	7.0
540	27.8	8.5	35.2	15.9	7.4
600	28.3	9.0	35.5	16.2	7.2
900	29.6	10.3	36.9	17.6	7.3

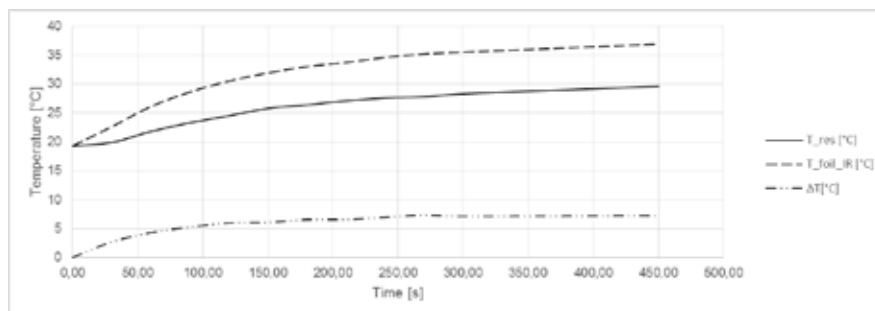

Fig. 6. The temperature variation for both systems

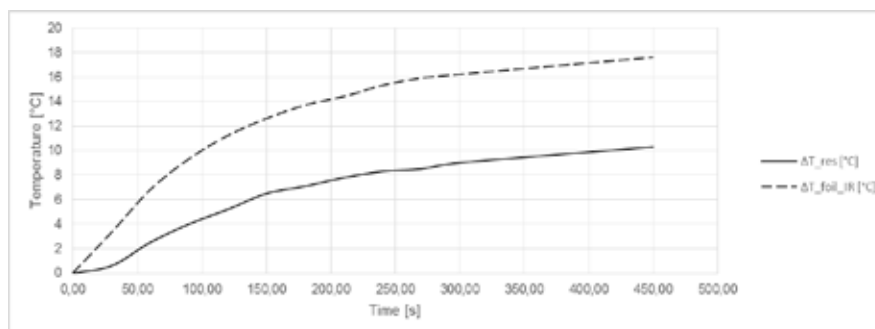

Fig. 7. The increase in temperature for both systems during the experiment

In figure 8 we can see the temperature values measured in three points on each seat and also the maximum temperature at seat level for both systems.

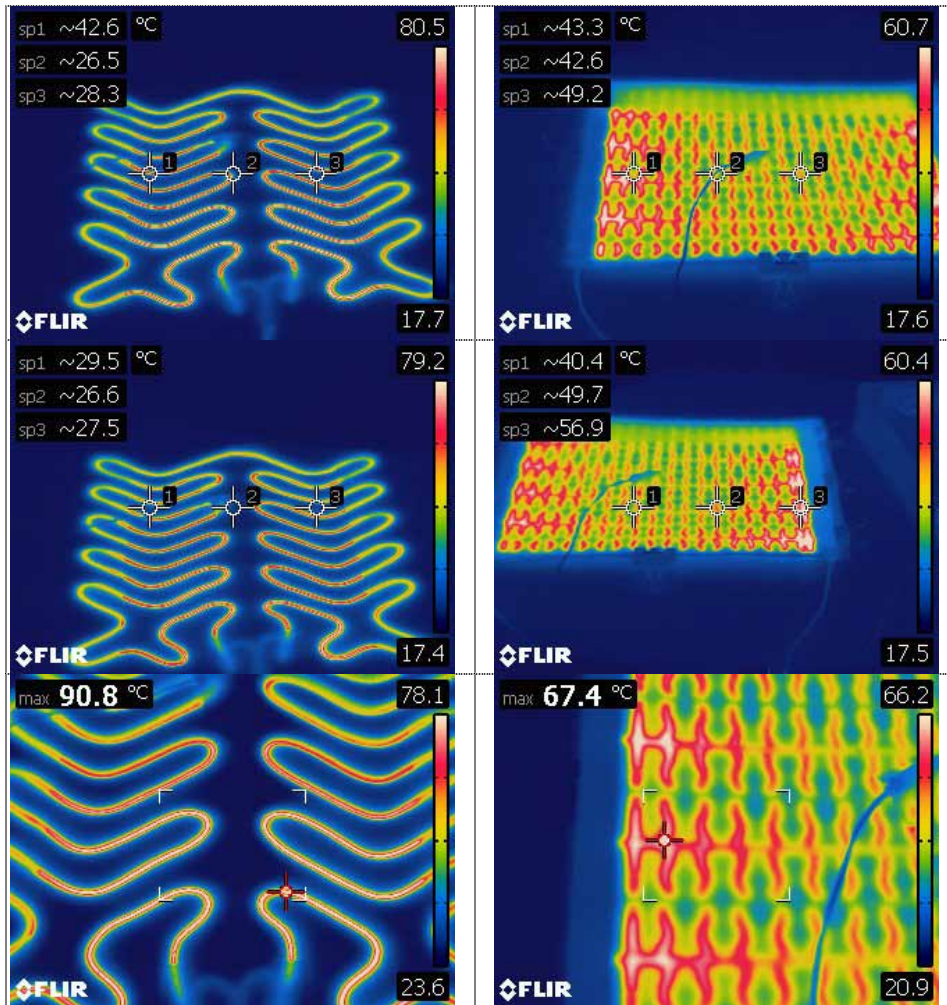

Fig. 8. The temperature values measured in three points

In the last part of this paper (figure 9) is shown a graphic that depicts the temperature evolution during the experiment for a seat heated using the IR foil system. (T₁ – temperature on the textile material at the seating area – region A, T₂ – temperature on the textile material in lumbar area, T₃ - temperature on the textile material in cervical area, T₄ - temperature on the textile material zone D – according to figure 5).

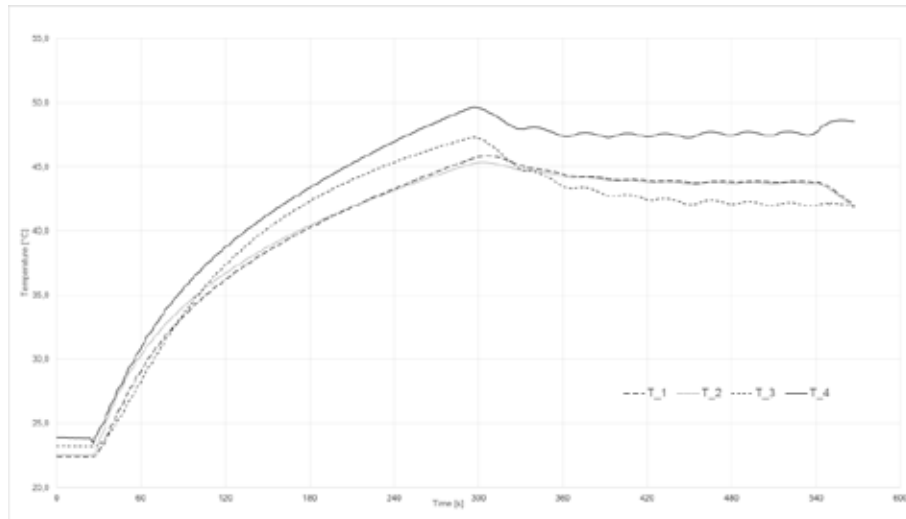

Fig. 9. Temperature evolution during the experiment for a seat heated using the IR foil system

From the chart we can observe a rapid increase of the temperature on each area of the seat (A, B, C and D), as well as the temperature that is maintained constant after the entry into operation of the thermostat.

4 Conclusions

The advantages of using an IR seat heating system versus the electrical resistance system includes the following:

Due to use of a carbon structures electrically connected in parallel, we obtain a rapid and long-lasting heating, as compared to other heating systems.

The heat flow is transmitted evenly on the human body from the first seconds of system operation, creating a sensation of thermal comfort much faster than electric resistance system.

Using radiant foil overlaid layers allow temperature rise and also a controlled dispensing of it depending on the physiological needs of passengers and conditions of use of motor vehicles.

The advantage of the parallel connection of radiant foil is that in the case of interruption of electrical resistance, the system no longer working compared with radiant foil, which in case of withdrawal of an item, it continues to operate.

The proposed systems offers an increased safety usage. The maximum temperature measured during functioning is 67,4°C for the IR foil compared with 90,8°C for electrical resistance system.

On the other hand, in this solution, one of the heating kits is located on the seat backrest causing an improvement of the thermal comfort for the back passengers, especially in the leg area and abdominal area. Therefore, the heat propagation for this heating system is transmitted mainly by conduction, but also by radiation and convec-

tion. The electrical command of the system is independent for the backrest zone, to assure energy savings.

References

1. Chien-Chou Chen: Heating apparatus for seat cushion of car, Patent no. US 7422277 B2 (2008)
2. Eckhard Scholz, Jakob Schweissgut, Bernhard Sepeur-Zeitz, Heike Walter: Headrest to be attached to car seat, comprising heating unit integrated in foam material, Patent no. DE102006013994 A1 (2006)
3. Thomas, Geisel: Heating device for vehicle seat of motor vehicle, particularly open passenger car, has heating element, by which body area, particularly head, shoulder and neck area of seat passenger are heated, Patent no. DE102007039423A1 (2009)
4. Oliver Rosier, Markus Roth, Reinhold Meier: Infrared heating device for warming upper body of e.g. driver of passenger car, has heat radiator arranged at rear side of mirror element of inner mirror i.e. inner rearview mirror, where mirror element comprises reflecting surface, Patent no. DE102012205873 A1 (2013)
5. Stefanescu, D., Leca, A.: Transfer de caldura si masa, Editura didactica si Pedagogica, Bucuresti (1983)
6. „Research and development of electrical, electronical and thermal systems, innovative technologies for sustainable mobility alternative, to increase the vehicle energetic efficiency, to reduce emissions and improve thermal comfort for passengers”, Research project P.O.S-C.C.E 2007-2013, Cod SMIS 50069, 2014-2015.
7. Ivanescu, M., Stancila, M., Ene C.A., Neacsu C.A.: Heated seat for a vehicle, Patent application no. A/10009/2015 OSIM/ Romania; Beneficiary : Renault Technologie Roumanie S.R.L, 2015.