

# Kinematic Optimization of the Rack and Pinion Steering-System of an Automobile: An Example

Adrian Ștefan Mazilu and Ion Preda

Transilvania University of Brasov, Brasov, Romania  
adrian\_mz193@yahoo.com, pion@unitbv.ro

**Abstract.** A properly designed steering system has direct correlation with the stability and safety of the automobile.

This paper presents a kinematic design example of a rack and pinion steering system combined with an independent front suspension.

The design considered the available space and cross-coupling with the vehicle suspension. Virtual models were created and further updated as the design progressed. A simplified geometrical model has been created first, and was corrected and improved within Catia CAE package.

**Keywords:** rack and pinion; steering kinematics; Ackermann steering; CAD; optimization

## 1 Introduction

The design of a steering system of an automobile must match the overall dimensions of the vehicle and the available space for the steering and suspension components. The designer must take into consideration the orientation and location of the engine relative to the front axle, the type of suspension, critical dimensions and intended use of the vehicle [1–7]. The availability of specialized software programs helps the automotive engineer expedite the design process, and eliminates the need for costly prototype testing. Such computer programs can be used for assembly and component design, engineering analyses and virtual simulation. In this paper it is presented an example of CAD package use in the kinematic design and refinement of the steering system mechanism of a passenger car.

## 2 Preliminary Analysis of Linkage Geometry

During steering, a correct positioning of the road wheels requires that the extensions of the centerline of all wheels intersect at a common point. At low side-slip angles, this point is located along the axis of the rear axle (this is the so called Ackermann condition), Fig.1. This condition can be satisfied only when the lateral forces acting upon the vehicle are negligible, and when the wheels perform pure rolling. Therefore,

the design of the steering system must commence with a kinematic optimization of the steering linkage.

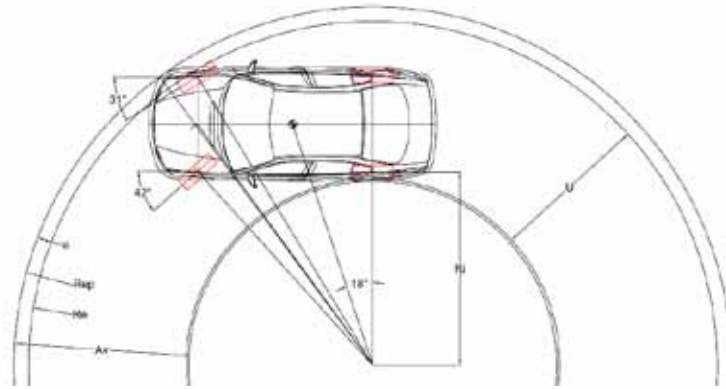
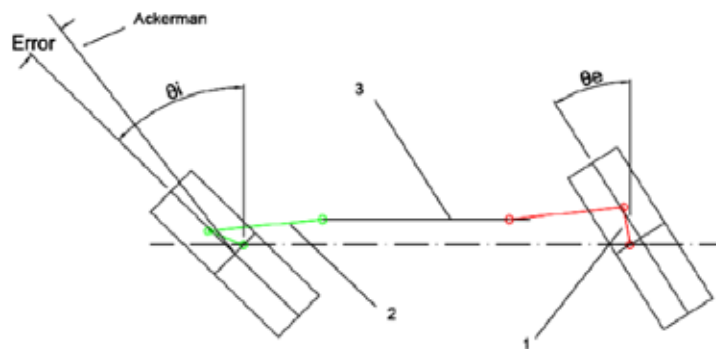

**Fig. 1.** Ackermann steering condition

A vehicle steering mechanism consists of two subsystems:

- the steering linkage serves to correlate the steering angle of the road wheels such that to conform with a steering principle chosen by the designer (the Ackermann's principle, for example);
- the steering-control mechanism transmits the steering wheel input by the driver to the steering linkage.

Early in the design process a kinematic analysis of the steering linkage must be performed. For example, the limit steered positions of the inner and outer wheels are imposed by the minimum turning radius of the vehicle, as Fig. 1 infers.



**Fig. 2.** Schematic of the rack and pinion steering linkage: 1 – steering arm; 2 – steering rod; 3 – steering rack;  $\theta_i$  and  $\theta_e$  – steering angles of inner and outer wheels

In a rack and pinion steering box, the rack is part of both the steering linkage and of the control mechanism. This is a simple and cost effective design, with reduced numbers of components that requires low maintenance. It is therefore the most widely used steering mechanism for cars and vans.

Fig. 2 presents the main components of a rack and pinion steering linkage for the case of a four-wheel vehicle with a steerable front axle and independent wheel suspension. This mechanism contains two steering arms 1, two steering rods 2 and the rack 3. It can also be seen the annotations for inner wheel cornering angle  $\theta_i$ , outer wheel cornering angle  $\theta_e$  and error between Ackermann angle and actual inner-wheel angle.

### 3 Steering Linkage Kinematic Optimization

The optimization of the steering linkage, as subsystem of the steering system requires at a minimum [8]:

- to find first an ideal correlation function  $\theta_{iw}=f(\theta_o)$  between the wanted inner steering-angle  $\theta_{iw}$  and an actual outer steering-angle  $\theta_o$ ;
- to identify the dimensions of the mechanism for which and ideal steering function is best approximated by the actual input-output function  $\theta_i=f(\theta_o)$  of the mechanism.

As indicated in reference [8], the ideal road-wheel correlation function  $\theta_{iw}=f(\theta_o)$  depends on numerous factors, of which the more important are the driving speed and the radius of turn. It means that an optimized steering system of a vehicle is one which provides for different driving conditions a good compromise of the vehicle dynamic performances.

For negligible lateral slip of the tires (i.e. the particular case of driving at low speed on horizontal roads), a  $\theta_{iA}=f(\theta_o)$  law according to Ackermann (and which is known to be a function of only of the wheelbase and wheel track of the vehicle, Fig. 1), may be adopted as ideal correlation function  $\theta_{iw}$ .

If lateral forces acting on the tires are not negligible (existing simultaneously with side slip), the turning center of the vehicle will move forward off the rear wheel axis [1]. Assuming a certain constant value for the lateral slip angles of the rear tires, the correlation function  $\theta_{iw}=f(\theta_o)$  can conform to Ackermann, but for the vehicle assumed to have, fictitiously, a shorter wheelbase [9, 8]. Therefore, in this study the Ackermann steering law will be considered as the ideal correlation function, and will be imposed to be best approximated by the rack and pinion linkage of the vehicle under consideration.

For the outer wheel angle  $\theta_e$  assumed to be the independent variable, the optimization of the steering linkage geometry is aimed to reducing the angular error at the inner wheel. This error is defined as the difference between the prescribed angle (for example the Ackermann angle) and the real steering-angle  $\theta_i$  of the inner wheel, as it is realized by the correlation mechanism.

The outer wheel angle of steer  $\theta_e$  was adopted as independent variable also because it is known to have a greater effect upon the vehicle dynamics due to the load transfer from the inner to the outer wheels.

In addition, the interference of the wheels with the car body and other neighboring parts when in their limit positions, are of concern to the design engineer.

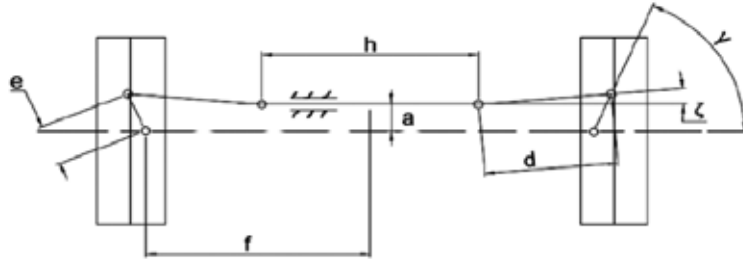

**Fig. 3.** Parameters of the steering system linkage:  $h$  - rack length;  $d$  - steering rod length;  $f$  - distance between the pivoting point of the wheel and the longitudinal axis of the vehicle;  $e$  - steering arm length;  $\gamma$  - angle of steering arm;  $\zeta$  - angle of steering rod;  $a$  - distance from rack axis to front axle axis

The dimensional parameters of the rack and pinion linkage are presented in Fig. 3. Some of these are usually imposed by the available space constraints [1, 8]. These are as follows:

- $f$  - the distance from the longitudinal axis of the vehicle to the pivoting point (the intersection between the false kingpin axis and a plane parallel to the ground at the rack axis level); the distance depends on the steering wheels track, wheel scrub radius and kingpin angle; it must be noted that the distance  $f$  in figure 3 differs (normally is shorter) as the corresponding distances in figures 1 and 4, which are measured at the ground level; this difference must be considered for a good computation of the kinematics of the linkage mechanism;
- $h$  - the length of the rack, imposed by the adopted transmission ratio of the steering system and the space necessary for the power boost (hydraulic cylinder or electric motor);
- $e$  - the length of the steering arm, limited in size by the available space inside the wheel rim; in [10] it is demonstrated that the rack and pinion linkage can generate identical correlation functions with different steering arm lengths, which allows to adopt its value accordingly with other requirements, non-related with linkage kinematics; but it must be noted that the leading or trailing position of the steering arm will have an important influence on the actual function  $\theta_i=f(\theta_o)$  generated by the linkage, will influence the steering compartment during frontal shocks on tires, and will impose a changed positioning of the pinion with respect to the rack (pinion under the rack for leading steering arm).

During the optimization process, all the other dimensions presented in Fig. 3 were modified:

- $a$  – the distance between the rack axis and the front axle’s axis;
- $\gamma$  – the angle position of the steering arm, corresponding to the straight-line traveling;
- $\zeta$  – the angle position of the steering rod.

There are numerous ways to optimize the design of the steering linkage. Works as [11–12] analyze the rack and pinion linkage, showing that, with good approximation, this may be considered a planar mechanism and its kinematics presents generally more than one optimum. A problem is that some of the steering linkages with optimized kinematics present configurations that are difficult or almost impossible to implement as practical designs.

The optimization method adopted in this study, similar with the one presented in [13], consist in minimizing the sum of the squared errors between the actual and ideal steering angles.

**Table 1.** Geometric parameters of five configurations considered during simulation

| Model no. | $\gamma$ [deg] | $a$ [mm] | $h$ [mm] | $d$ [mm] | $f$ [mm] | $\zeta$ [deg] |
|-----------|----------------|----------|----------|----------|----------|---------------|
| 1         | 68             | 90       | 660      | 396.1362 | 674      | 5.094         |
| 2         | 68             | 110      | 660      | 394.8634 | 674      | 2.20173       |
| 3         | 68             | 80       | 660      | 397.149  | 674      | 6.53068       |
| 4         | 70             | 90       | 660      | 391.9098 | 674      | 5.39655       |
| 5         | 67             | 90       | 660      | 398.2259 | 674      | 4.93653       |

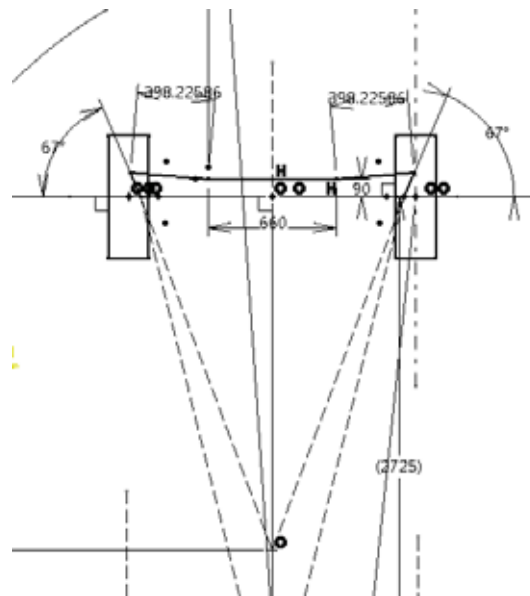

**Fig. 4.** Catia 2D-model of a leading rack steering linkage

The link lengths and position angles were modified in a systematic way so that to cover an entire variation interval, adopted in conformity with the vehicle's dimensions. The finding process of the optimal dimensions was repeated with small steps near the good configurations. Some of the parameter values used throughout the linkage configurations optimization are presented in the Table 1.

The authors experience in using CAD software [8, 14] was used to graphical represent the tested configurations, in order to have a better understanding of the linkage behavior. In the Fig. 4 it is presented the Catia 2D-model used for the parameter optimization, which permitted the easy change of linkage positions and the animation of the model.

During the simulation, the change of some parameters could be observed and the effect analyzed. These were: the rack's left-right displacement, the outer and inner steering angles, the position of the turning center or the vehicle's apparent wheelbase during steering.

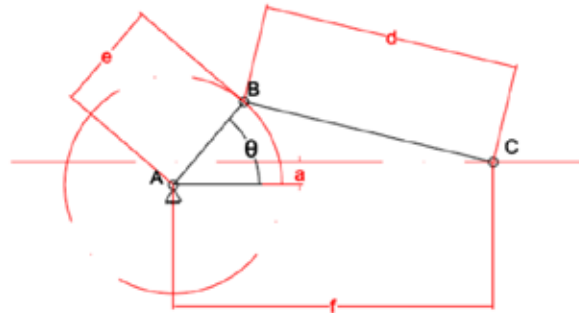

Fig. 5. The rack and pinion steering linkage considered as an offset slider-crank mechanism

In parallel with the analysis done using Catia software, a mathematical model of the mechanism has been developed. This model is equivalent to an offset slider-crank mechanism (Fig. 5), with the steering arm angle  $\theta$  as input [1] and the distance  $f=AC$  between pivoting point  $A$  and rack end  $C$  as output. The other approach, considering the rack as driving element, it was also used [Fig. 6]. The values were compared to the ones obtained in the CAD software to confirm the computation results.

## 4 Results

Some results of the analysis are shown in the Fig. 6. One can observe the difference between inner and outer steering angles,  $\Delta\theta=\theta_i-\theta_e$ , as function of outer steering angle  $\theta_e$ . The Ackerman's steering angle, also shown on this graph, reveals the error variation for some considered models (with parameters indicated in the Table 1).

Other data obtained from the same simulations on the five steering models are presented in the Fig. 7: the difference between the actual inner-angle and the Ackermann inner-angle,  $\Delta\theta_\Lambda$ , as function of outer-angle  $\theta_e$ . As it can be observed, the deviation from Ackermann condition is small (under 1 deg) for small and medium steering an-

gles, proving that the rack and pinion linkage is able to ensure good wheels correlation during cornering at medium and high speeds. The largest deviation from Ackermann condition occur at large steering angles, situation commonly present for vehicle maneuvering at low speeds (during parking, for example).

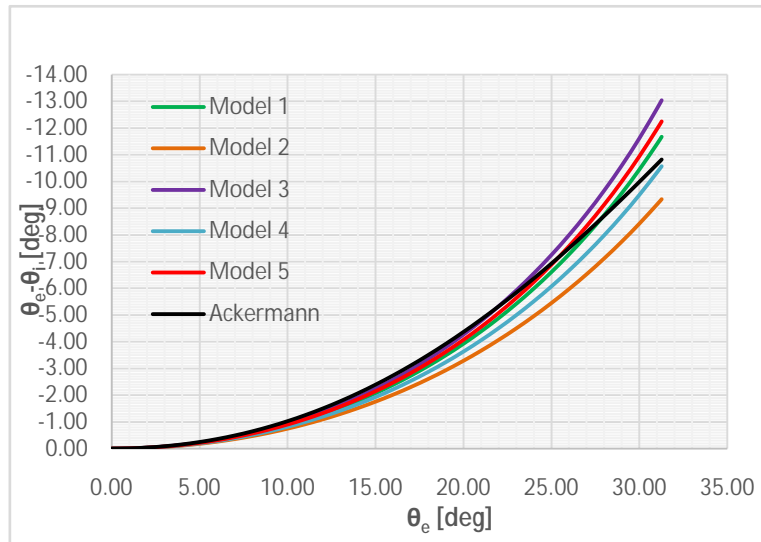

**Fig. 6.** Angle difference  $\Delta\theta=\theta_i-\theta_e$  as function of outer steering angle  $\theta_e$

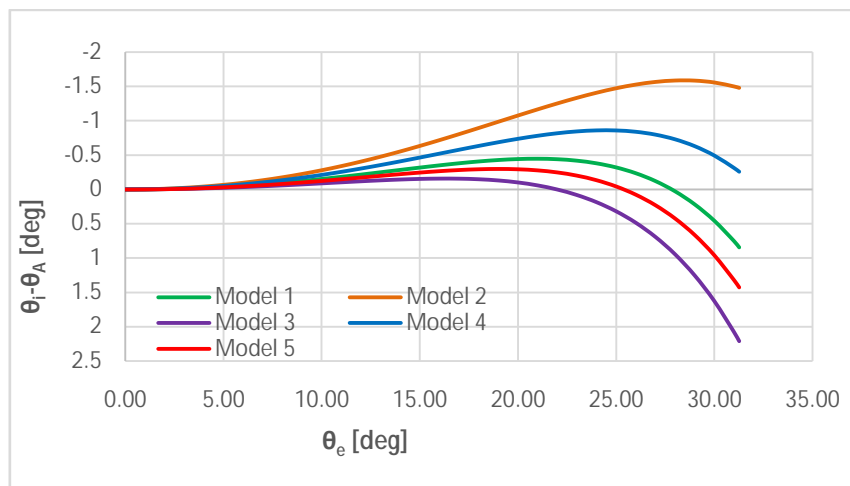

**Fig. 7.** Deviation of inner wheel steering angle from Ackermann inner wheel angle as function of outer wheel steering angle

Comparing the performances of the studied linkages, the configuration of the model number 5 appeared as the best option for the case of the considered vehicle. The

result was obtained mathematically by choosing the solution that ensures the minimum value of the sum of the squared errors (computed with a step of 1 deg  $\theta_0$ ), weighted such as to consider bigger values for small to mean values of steering angles, which corresponds to high vehicle speeds.

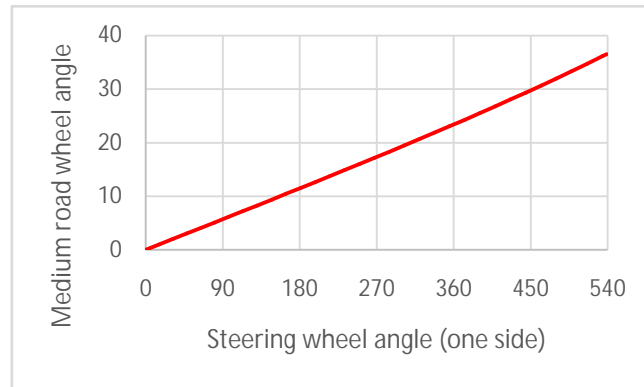

**Fig. 8.** Mean road-wheel angle as function of driver steering-wheel angle



**Fig. 9.** Overall steering ratio (steering-wheel angle divided by road-wheel angle) as function of steering wheel angle

A value of 15 was adopted for the mean overall steering-ratio of the considered vehicle (the steering-wheel angle divided by the medium road-wheel angle). Considering the steering-wheel angle correlation with the rack displacement, two more analyses were made:

- the variation of the “mean” road-wheel steering angle (of a “single-track” equivalent vehicle) as function of steering-wheel angle (as it is input by the driver), Fig. 8;
- the variation of the overall steering-ratio as function of steering-wheel angle, presented in Fig. 9.



As it can be seen from these last two figures, the overall steering-ratio of the rack and pinion steering system is not constant, but rather shows a reduction of its value with about 10% at the maximal steering angle compared to the ratio corresponding to the vehicle's straight-line driving.

With the parameters defined through the optimization realized on the 2D-model of the rack and pinion linkage, a 3D-model of the front axle was realized in Catia (Fig. 10), which may be further tuned, taking into account the spatial configuration of the mechanism and the influence of the suspension.

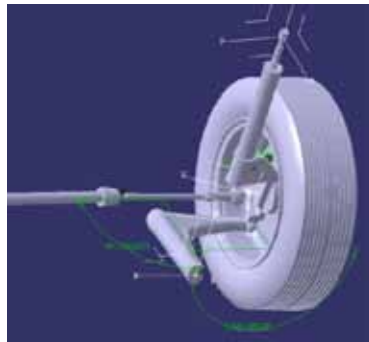

**Fig. 10.** 3D-model of the front axle (MacPherson suspension and rack and pinion steering)

Based on the study presented here, the following suggestions may be made for the design of the rack and pinion steering-linkage (Fig. 3) in order to best approximate a steering law close to the Ackermann principle:

- if possible, a small value of the steering rod angle  $\zeta$  will be adopted;
- the steering arm angle  $\gamma$  is close to optimum for a value that leads to the intersection of both arms axes at approximately three quarters of the vehicle's wheelbase;
- the optimum distance  $a$  between the rack axis and the front axle's axis depends on the vehicle dimensions;
- if the rack is positioned in front of the axle (leading linkage), but is small, the error is significantly reduced;
- if the steering arms are positioned in front of the axle (leading linkage), the rack and pinion linkage approximates better the Ackermann steering law;
- the value of rack length  $h$  must be small enough in order to obtain an optimum value for the steering rod length  $d$ ; also, a maximized length  $d$  will lead to a smaller bump-induced steering, a factor with an important influence in the steering-and-suspension systems compatibility.

## 5 Conclusions

The study presented in this paper has shown a possible approach to the design, and optimization of a complex mechanism such as the steering system of a passenger car. The project started with the system requirements, and the dimensions of the mechan-

ism were progressively adapted and optimized based on the calculation of the individual. Optimization has been made in several steps, firstly starting with a research of most used parameters on modern vehicles, following with a simplified analysis to obtain a good geometric improvement from 2D-models and data extracted for the subassembly computation. Later, a 3Dmodel has been created in order to observe the compatibility of the designed vehicle components.

**Acknowledgements.** The comments and suggestions of improvement of Dr. Petru A. Simionescu from Texas A&M University Corpus Christi are gratefully acknowledged.

## References

1. Alexandru, P., Dudiță, F., Jula, A., and Benche, V.: Mecanismele direcției autovehiculelor (Motor Vehicles' Steering Mechanisms). Bucharest: Editura Tehnica (1977)
2. Untaru, M., Frățilă, G., Pojincu, G., Seitz, N., Tabacu, I., Pereș, G., Macarie, T.N.: Calculul și construcția automobilelor (Calculus and Construction of Motor Vehicle). Editura Didactică și Pedagogică, București (1982)
3. Gillespie, T.D.: Fundamentals of Vehicle Dynamics, SAE, Warrendale, USA (1992)
4. Reimpell, J., and Stoll, H.: The Automotive Chassis: Engineering Principles, Arnold Publishers, London (1996)
5. Mitschke, M. and Wallentowitz, H.: Dynamik der Kraftfahrzeuge (Dynamics of motor vehicles), Berlin, Springer (2004)
6. Genta, G. and Morello L.: The Automotive Chassis. Vol. 2 - System Design. Springer (2009)
7. Pauwelussen, J.: Essentials of Vehicle Dynamics. Elsevier (2015)
8. Preda, I., Covaciu, D., and Ciolan, G.: Design approach for the vehicle's steering linkage fitted on rigid axle. 3<sup>rd</sup> International Congress Science and Management of Automotive and Transportation Engineering SMAT, University of Craiova, Romania (2014)
9. Preda, I., and Ciolan, G. Vehicle mathematical model for the study of cornering. Annals of the Oradea University. Fascicle of Management and Technological Engineering, Volume XI (XXI), Nr. 2/1.22-32 (2012)
10. Simionescu, P.A., and Smith M.R.: Initial Estimates in the Design of Rack-and-Pinion Steering Linkages. Journal of Mechanical Design, Vol. 122 (June 2000), pp.194-200
11. Zarak, C.E. and Townsend, M.A.: Optimal design of rack-and-pinion steering linkages. Transaction of ASME 220, Vol. 105 (1983)
12. Collard, J.F., Duysinx, P., and Fiset, P. Optimal Synthesis of Planar Mechanisms via an Extensible-Link Approach. Struct Multidisc Optim (2010) 42:403–415, Springer (2010)
13. Preda, I., Ciolan, G., and Ispas, N. Optimization study of a car suspension-steering linkage. International Conference of Mechanical Engineering ICOME 2010, Tome II, pp. 675-682, Universitaria Publishing House, Craiova (2010)
14. Simionescu, P.A.: MeKin2D: Suite for Planar Mechanism Kinematics. ASME 2016 Design Engineering Technical Conferences and Computers and Information in Engineering Conference, Charlotte, USA (2016)