



CONTRIBUTIONS TO STUDY ON THE EFFICIENCY OF SEPARATION OF THE IMPURITIES FROM WASTE WATER BY MEANS OF SERIES MOUNTED TANGENTIAL FILTERS

Daniela Zărnoianu¹, Simion Popescu²

¹ Transilvania University of Brasov, Romania, e-mail: daniela.zarnoianu@yahoo.com

² Transilvania University of Brasov, Romania, e-mail: simipop38@yahoo.com

Abstract. The paper presents the methodology and the experimental research installation destined to study the efficiency of impurities separation from the wastewaters by the use of the tangential filters connected in series. The experimental installation (pilot installation) used consists of two tangential filters mounted in series, with filtering elements with stainless steel sieves, having a fineness of 475 μm , and 80 μm . To establish the filtration efficiency to a given feed flow rate were determined by measurements the liquid pressures and concentrations of the suspension in clear (in mg/l) at the entrances and at the exits from the filters, after certain durations of operation (throughout of 60-minute). Finally are presented the conclusions on the efficiency of separation of mechanical impurities of the analyzed filtration system.

Keywords: wastewater, tangential filtration, series mounted tangential filters, experimental installation, filtration efficiency

1. INTRODUCTION

Filtration is a process of separation of solid impurities from fluids by their flow through permeable filtering environments (granular layers, sieves, membranes), generally called filters. In the case of waste water the filtration processes are influenced by a number of factors, the most important being: the nature and characteristics of the fluid suspension to be filtered (the size, nature and impurities form, density, concentration), the nature and characteristics of the filtering environment and the filtration conditions (filtration flow rate, pressure, temperature, filtration procedure) [2]. There are basically two ways to make a filtration mechanism: by retaining the solid impurities on the surface of the filtering environment pores and by retaining the solid impurities in the filter. Depending on the direction of fluid flow relative to the filter medium, the fluid filtration can be done in three different ways: by surface flowing, by deep flow and by tangential flow [1].

At the surface and depth filtration, the liquid flow passing through the filter element declines rapidly towards zero, the pressure drop increases exponentially due to the formation of an impurities layer with an increasing thickness. The filtration by tangential flow (cross-flow filtration), usually is called *tangential flow filtration (TFF)* and is characterized by the fact that the direction of fluid flow is parallel to the surface of the filter, the liquid making a "scavenging" of the filter, thus preventing the formation by agglomeration of a layer of impurities above the filtering surface, so that it maintains the filter functionality by reducing the effect of dirtying (clogging). Regeneration of the filter permeability structure can be done by washing the filter element by directing the liquid in counter-flow [4].

The tangential flow filtration (cross-flow filtration), is a form of a dynamic filtration. In cross-flow filtration the build-up of a filter cake on the surface of the filter media is hindered by a strong flow tangentially (parallel) to the filter surface. Clear liquid passes through the filter medium (mostly a membrane) and the concentrate (respectively the retentate) with higher concentrations of the rejected components is discharged from the filter. The cross-flow stream over the filter media has often a linear velocity in the range of 1 to 6 m/s. This cross-flow is achieved in most cases by pumping the suspension through a membrane module, which e.g., contains the membrane in form of a bundle of membrane tubes [3,5].

Tangential filtration is a more efficient method compared with the filtration of surface and of depth, because most of the liquid to be filtered flows parallel to the surface of the filter, a much smaller part flowing through the filter membrane. Due to the effect of "sweeping" and of cleaning is prevented premature the filters clogging and

the occurrence of differences in concentration of the filtered fluid. Tangential flow filtration allows the use of much higher flows than to the perpendicular flow (normal), of surface and of depth, being used increasingly in the industrial processes [3]. Regeneration of the filter permeability structure can be done by washing the filter element by directing the liquid in counter-flow [4]

Tangential filtration is a more efficient method compared with the filtration of surface and of depth, because most of the liquid to be filtered flows parallel to the surface of the filter, a much smaller part flowing through the filter membrane. Due to the effect of "sweeping" and of cleaning is prevented premature the filters clogging and the occurrence of differences in concentration of the filtered fluid. Tangential flow filtration allows the use of much higher flows than to the perpendicular flow (normal), of surface and of depth, being used increasingly in the industrial processes[2].

After a certain operating time of the filter is possible the plugging (clogging) the pores or orifices of the filtering element, with negative effects on the efficiency of the filtration process. To eliminate this inconvenience the filter is provided with the possibility of performing a washing procedure by the inverse filtration. For determining when it is necessary the inverse filtering, the inlet and outlet connections from filter are coupled through a differential pressure gauge, which measures the pressure difference between the entrance of the wastewater and the exit of the filtrated liquid. In practice, cleaning the filters by washing performed by inverse filtering is recommended when the differential manometer indicates a pressure drop of more than 2 bar between the filter inlet and outlet.

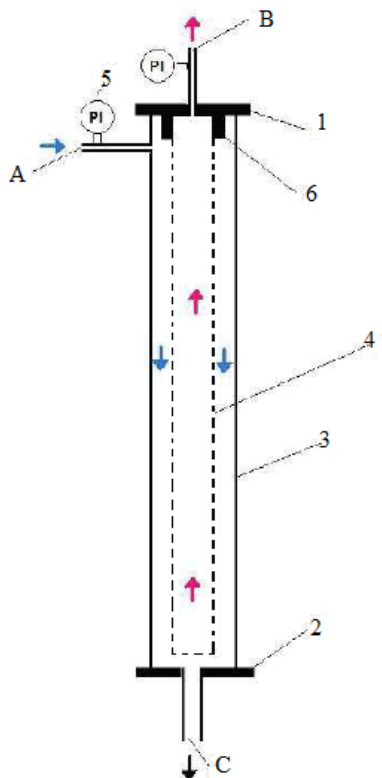

Figure 1. The constructive and functional diagram of a tangential flow filter:

A - liquid inlet subjected to filtration; B- filtered liquid outlet (having passed through the filtering element); C- evacuation fluid that has not passed through the membrane (the concentrated liquid relative to the substance whose concentration it is desired to be increased):

1- upper lid; 2- lower lid; 3- filter body; 4- filtering element; 5- differential pressure gauge connection fittings; 6- fixing plate of the filtering element.

2. MATERIALS AND METHODS

The basic objective of the undertaken researches consists in experimental determination of the optimum moment at which is imposed the washing of tangential filters through the reverse filtering operation. For this is used the method of the measurement of pressure differences between Ins and Outs of filters, whose values depend on the degree of fouling (clogging) of filter elements.

For the experimental study of the functional behaviour and of the filtration efficiency when using tangential filtration systems of the industrial waste water was designed and built an experimental installation (pilot plant) with two filtration filters (Fig. 2), which allows retaining the solid suspensions from 4000 mg / l up to a value of approx. 400 mg / l. The experimental installation consists of two tubular filtering modules serially connected: the coarse filtration module F1 equipped with filter with stainless steel sieves having a fineness of 475µm and the microfiltration module (fine filtration) F2, equipped with stainless steel filter with sieves having a fineness of 80 µm. To measure the flow discharged by the pump 1 is used the electromagnetic flowmeter FIQ (type

YOKOGAWA) and for measuring the pressures are used the pressure gauges PI (type Bourdon tube type with separation membrane MS) All the elements of the installation are mounted on a supporting plate. The waste water subjected to analysis is stored in the tank V1 (with a capacity of approx. 200 l) and is sent in the filtration system by means of the centrifugal pump P1. In the first stage the water reaches the coarse filter F1 (with the sieve of 475 μm), at the upper part being discharged the filtered liquid (who has passed through the filtering element F1) and at the the lower part occurs the discharge in the tank V2 (approx. 60 l) of the liquid with impurities (the liquid that has not passed through the filter membrane F1. In the second stage, the filtered liquid into the filter F1 reaches into the fine filter F2 (with the sieve of 80 μm), out of which at the upper side is discharged the filtered fluid which is collected in the tank V4 (approx. 200 l), and at the the lower part occurs the discharge in the tank V3 (approx. 50 l) of the liquid with impurities which has not passed through the filter F2 . The filtrate quality is targeted in the clear liquid accumulated in the tank V4. To clean (desilting) the filters is used the water from the current network (the circuit marked with green), with exhaust in the system slurry / sterile of the two filters. To determine the effectiveness of the filtration system tested in the tank V1 was introduced a wastewater with an initial concentration of suspensions of approx. 4.000 mg/l.

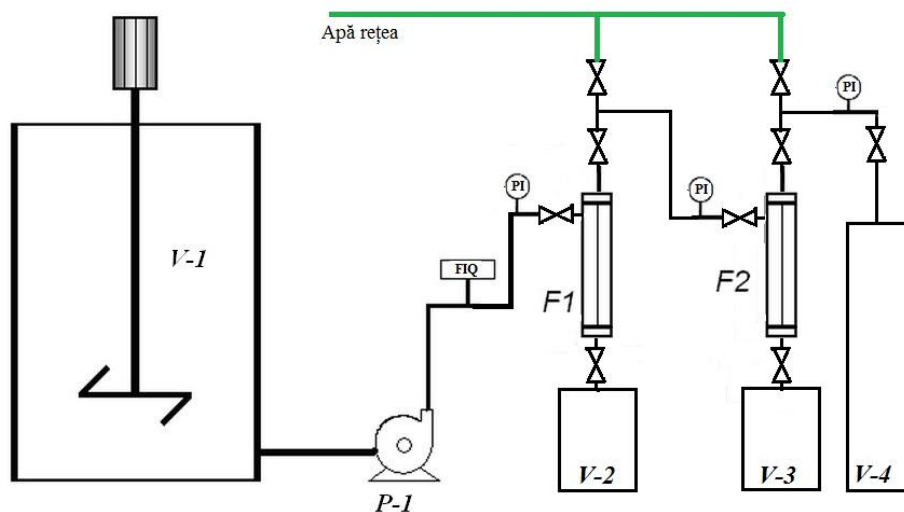

Figure 2: The scheme of the experimental plant (pilot plant) with two tangential filters coupled in series: 1-tank (V-1) with waste water that will be submitted to filtration; 2- hydraulic pump (P1) for supplying the filters ; 3-. electromagnetic flowmeter (FIQ) ; 4- manometers (PI) ; 5. coarse filter element (F1) with 475 μm steel sieves ; 6- fine filter element (F2) with steel sieves of 80 μm ; 7- tank (V2) to collect slurry / sterile resulting from the coarse filter F1 ; 8- tank (V3) to collect slurry / sterile resulting from the fine filter F2; 9- tank (V4) to collect the filtered product (clear)

After certain durations of operation of the filtering installation, in the range of from 0 to 60 min, were measured the pressures at the gauges mounted in the filter F1 entry and at the exits from the filters F1 and F2 and were determined by measuring the concentrations of the mechanical suspensions (in mg/l). The concentration of the liquid suspensions was determined by gravimetric analysis of the taken samples.

3. RESULTS AND DISCUSSION

The time variations of the pressures and concentrations of the mechanical suspensions from liquid experimentally determined at the outflows from the filters of the filtering installation are presented in Table 1.

Table 1: The variations in time of the suspensions pressures and concentrations l at the entry into F1 filter and the goings from the filters F1 and F2

Time	Pressure before F1	Pressure at the exit of F1	Pressure at the exit of F2	Concentration suspension before the F1	Concentration suspension at the exit of F1	Concentration suspension at the exit of F2
min	bar	bar	bar	mg/l	mg/l	mg/l
0	3	2.1	0.9	4058	1059	587
20	3.2	2.2	1.1	4058	826	436
40	3.4	2.6	1.2	4058	514	325

60	4	3.1	1.3	4058	468	216
----	---	-----	-----	------	-----	-----

Variations in time of the pressures (Fig. 3) and of the suspensions concentrations in clear water (Fig. 4) at the inlets and outlets from the filters of the installation allowing an analysis of the filtering process conducted by the pilot plant used.

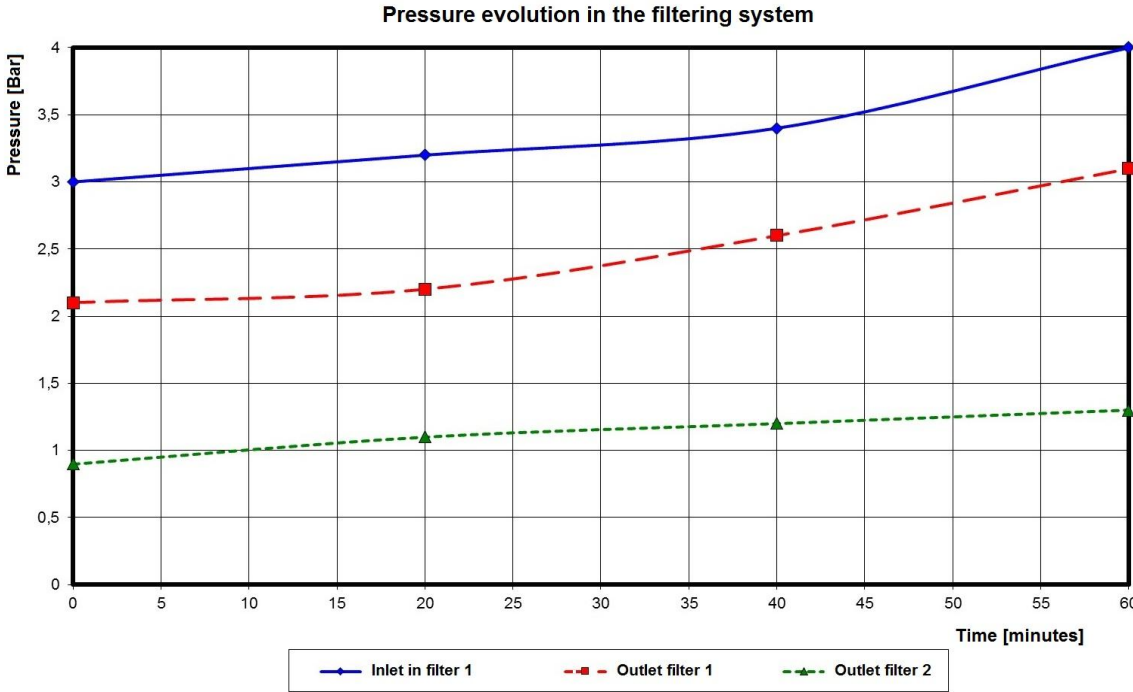

Figure 3. Variation in time of the pressures in filtering system at the entrance into the filter F1 and the goings of the filters F1 and F2

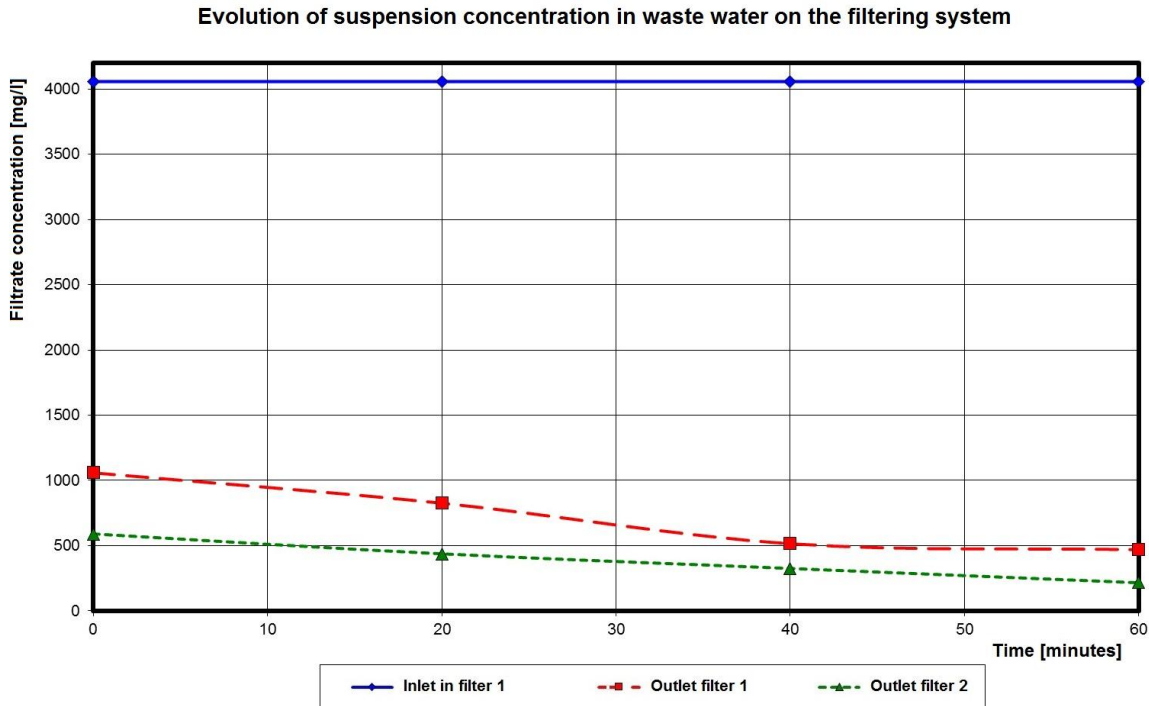

Figure 4: Variation in time of the suspension concentration in the waste water in the filtering system at the entrance into the filter F1 and the goings of the filters F1 and F2

4. CONCLUSIONS

From the analysis of the results presented as tables and graphics revealed the following conclusions:

- the pressures at the entrance into the first filter (coarse filter) and at the outlet of the both filters increase with the duration of the filtration process;
- the first filter (coarse filter) retained around 95% of the suspensions mass contained in the waste water analyzed;
- by using the system with tangential filters coupled in series the suspension concentration from the analyzed wastewater was reduced from the original value of approx. 4000 mg/l to a final value of approx. 200 mg/l in the filtered liquid (clear), obtaining a reduction of over 90% of the initial content of mechanical suspensions from the wastewater.

REFERENCES

- [1]. Rivet, G., Guide de la separation liquide-solide, Ed. IDEXPO, Cachan, 1985.
- [2]. Rus, F. Operații de separare în industria alimentară. Editura Universității Transilvania, Brașov, 2001.
- [3]. Sutherland, K., Filters and Filtration Handbook, 5th ed., Elsevier Butterworth-Heinemann, Amsterdam 2008.
- [4]. Tchobanoglous, G., Burton, F.L and Stensel, H.D. Wastewater Engineering. (4th Edition). McGraw-Hill Book Company, 2003.
- [5]. Wakeman, K. and Tarleton, E. S., Solid-/liquid Separation, 1st Ed., Elsevier, Oxford, 2005