



5<sup>th</sup> International Conference  
"Advanced Composite Materials Engineering"  
COMAT 2014  
16-17 OCTOBER 2014, Brasov, Romania

## ON THE STRESS INTENSITY FACTOR IN BENDING

Cornel Bit <sup>1</sup>

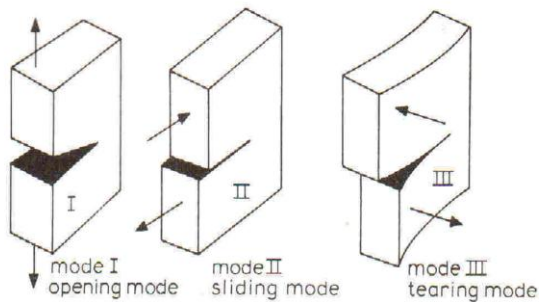
<sup>1</sup> TRANSILVANIA University, Braşov, ROMANIA, e-mail: [cbit@unitbv.ro](mailto:cbit@unitbv.ro)

**Abstract:** The paper presents a comparison among different analytical expressions for the stress intensity factor used in fatigue crack propagation analysis in pure and simple bending. A new analytical expression for the stress intensity factor has been proposed.

**Keywords:** crack, fatigue, stress intensity factor

### 1. INTRODUCTION

Within the context of the *Linear Elastic Fracture Mechanics* this paper is concentrated on the analytical expressions of the stress intensity factor  $K$  for a member in bending that represents a fundamental parameter in fatigue investigations. In many engineering applications the study of the fatigue crack propagation requires the use of a specimen having a pre-existing crack  $a$  (Fig. 1). To know the analytical expression of the stress intensity factor in such a case represents a very important issue.



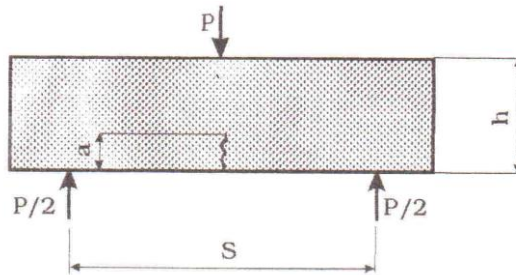
**Figure 1a:** The three modes of cracking



**Figure 1b:** The fatigue crack propagation front

On the other hand it is important to know that the propagation of a fatigue crack may be determined by three different modes the involved specimen is stressed in (Fig. 1a). The first mode is represented by the “opening mode” determined by the normal stresses developed at this level. In such a case the displacement of the crack surfaces are perpendicular to the plane of the crack. The next two modes of cracking are determined by shearing stresses. In such cases the displacement of the crack surfaces take place in the same plane with the plane of the crack. All the theories concerning the fatigue crack propagation in different materials and in different environmental conditions have been constructed on these three main modes of cracking. It is also important to underline that the fatigue crack front propagates on a certain distance within each fatigue cycle as shown in Fig. 1b. To study the behavior of the materials subjected to fatigue when the specimens are in bending, an initial study of the stress intensity factor is required. This is the subject of the present paper.

## 2. A COMPARISON AMONG DIFFERENT ANALYTICAL EXPRESSIONS OF THE STRESS INTENSITY FACTOR FOR THE INVESTIGATED SPECIMEN IN SIMPLE AND PURE BENDING



**Figure 1:** Fatigue crack study specimen

Depending upon the geometry and loading, in engineering publications there are specified different computation formulas for the stress intensity factor corresponding to the specimen represented in Fig.1. In [2] the relation proposed for pure bending (Fig. 2) is represented by a table function:

$$K = \frac{6M}{(h-a)^{3/2}} \cdot g\left(\frac{a}{h}\right), \quad (1)$$

where the function  $g(a/h)$  has been described in Table 1.

In Fig.3 the graphical representation of the table function  $g(a/h)$  has been shown while, through a polynomial fitting, the analytical expression of function  $g(a/h)$  is:

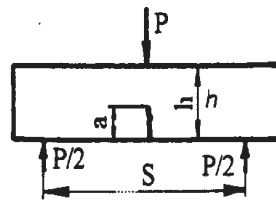
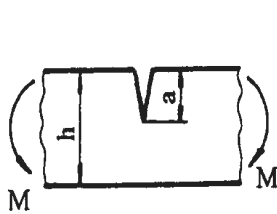
$$g\left(\frac{a}{h}\right) = 4.427\left(\frac{a}{h}\right)^3 - 5.952\left(\frac{a}{h}\right)^2 + 2.791\left(\frac{a}{h}\right) + 0.2468. \quad (2)$$

In this way, the analytical expression for the stress intensity factor corresponding to the investigated case becomes:

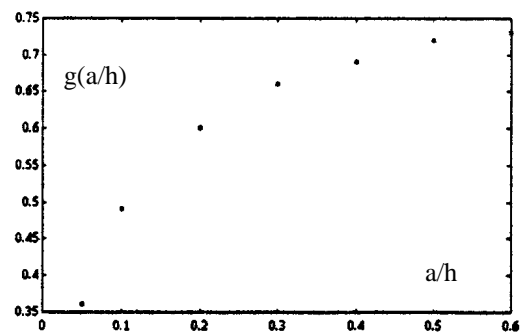
$$K = \frac{6M}{(h-a)^{3/2}} \left[ 4.427\left(\frac{a}{h}\right)^3 - 5.952\left(\frac{a}{h}\right)^2 + 2.791\left(\frac{a}{h}\right) + 0.2468 \right]. \quad (3)$$

**Table 1:** Function  $g(a/h)$

a/h	0.05	0.1	0.2	0.3	0.4	0.5	0.6
G(a/h)	0.36	0.49	0.6	0.66	0.69	0.72	0.73

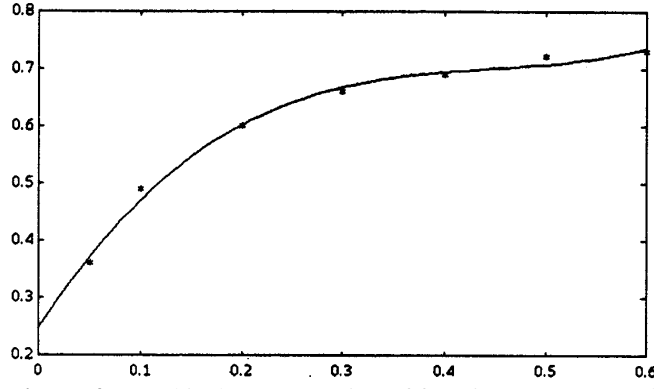


**Figure 2:** Specimens corresponding to relations (1) and (2) respectively



**Figure 3:** Graphical representation of function  $g(a/h)$  by points

Using the same reference system, in Fig. 4 the two graphs of function  $g(a/h)$  have been represented.



**Figure 4:** Graphical representation of function (2) compared with that of function  $g(a/h)$

In case of a specimen in simple bending, Fig.2b, in [1] the following computation relation has been proposed:

$$K = \frac{P \cdot S}{Bh^{3/2}} \left[ 2.9 \left( \frac{a}{h} \right)^{1/2} - 4.6 \left( \frac{a}{h} \right)^{3/2} + 21.8 \left( \frac{a}{h} \right)^{5/2} - 37.6 \left( \frac{a}{h} \right)^{7/2} + 38.7 \left( \frac{a}{h} \right)^{9/2} \right], \quad (4)$$

where B represents the specimen width. Adapted to the case of Fig. 2, relation (4) becomes:

$$K = \frac{4M}{Bh^{3/2}} \left[ 2.9 \left( \frac{a}{h} \right)^{1/2} - 4.6 \left( \frac{a}{h} \right)^{3/2} + 21.8 \left( \frac{a}{h} \right)^{5/2} - 37.6 \left( \frac{a}{h} \right)^{7/2} + 38.7 \left( \frac{a}{h} \right)^{9/2} \right]. \quad (5)$$

It is to be noted that the stress intensity factors refer to the 1<sup>st</sup> mode of cracks propagation (tension). Concerning the case of Fig. 2b, in [3] a similar relation has been proposed:

$$K = \frac{P \cdot S}{Bh^{3/2}} \frac{3 \left( \frac{a}{h} \right)^{1/2} \left[ 1.99 - \frac{a}{h} \left( 1 - \frac{a}{h} \right) \cdot \left( 2.15 - 3.93 \left( \frac{a}{h} \right) + 2.7 \left( \frac{a}{h} \right)^2 \right) \right]}{2 \left( 1 + 2 \left( \frac{a}{h} \right) \right) \cdot \left( 1 - \frac{a}{h} \right)^{3/2}}. \quad (6)$$

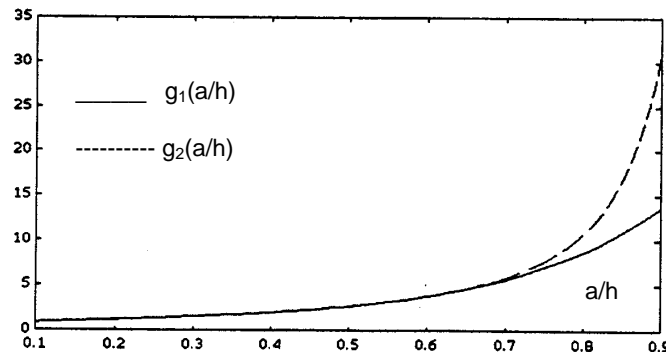
For the case represented in Fig. 2a, it follows that the stress intensity factor becomes:

$$K = \frac{4M}{Bh^{3/2}} \frac{3 \left( \frac{a}{h} \right)^{1/2} \left[ 1.99 - \frac{a}{h} \left( 1 - \frac{a}{h} \right) \cdot \left( 2.15 - 3.93 \left( \frac{a}{h} \right) + 2.7 \left( \frac{a}{h} \right)^2 \right) \right]}{2 \left( 1 + 2 \left( \frac{a}{h} \right) \right) \cdot \left( 1 - \frac{a}{h} \right)^{3/2}}. \quad (7)$$

The functions (5) and (7) may be expressed as:

$$K_{(5)} = \frac{4M}{Bh^{3/2}} g_1 \left( \frac{a}{h} \right) \quad \text{and} \quad K_{(7)} = \frac{4M}{Bh^{3/2}} g_2 \left( \frac{a}{h} \right). \quad (8)$$

In Fig. 5 the functions  $g_1(a/h)$  and  $g_2(a/h)$  have been represented.

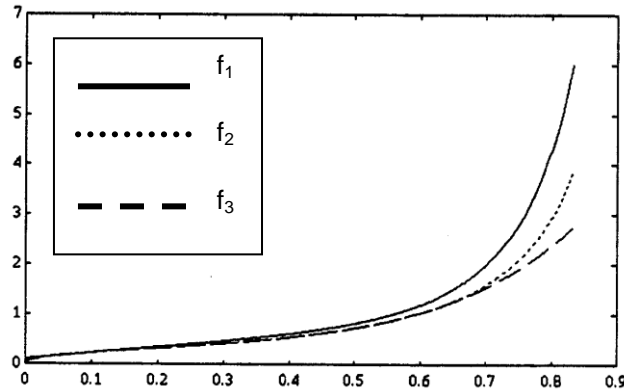


**Figure 5:** Graphical representation of functions  $g_1(a/h)$  and  $g_2(a/h)$

In Fig. 5 it is to be noticed that, for values of the ratio  $a/h$  greater than 0.7,  $g_1$  and  $g_2$  become different. For  $B=1$  the three mathematical expressions of the stress intensity factor may be written in a concentrated form as:

$$K_{(i)} = M \cdot f_{(i)}(a, h), \quad (9)$$

where  $i=1,2,3$  corresponds to the forms (3), (5) and (7) of the stress intensity factor respectively.



**Figure 6:** Graphical representation of functions  $f_1$ ,  $f_2$  and  $f_3$

In Fig. 6 the graphical representation of functions  $f_i$  ( $i=1,2,3$ ) have been represented. We note that there is a very good concordance among the three forms of the stress intensity factor, especially for low values of the ratio  $a/h$  – which, in fact, have the most frequently use within the cracks propagation study for the above discussed type of loading and geometry.

### 3. CONCLUSION

For a specimen with a pre-existing crack on one side – Fig. 1, subjected to pure bending the following simple analytical relation has been proposed:

$$K_I = \frac{6M}{B(h-a)^{3/2}} \cdot \left[ 4.427 \left( \frac{a}{h} \right)^3 - 5.952 \left( \frac{a}{h} \right)^2 + 2.791 \left( \frac{a}{h} \right) + 0.2468 \right], \quad (10)$$

where  $B$  is the specimen width while the stress intensity factors corresponding to the 2<sup>nd</sup> and the 3<sup>rd</sup> modes of cracks propagation being  $K_{II}=K_{III}=0$ .

### REFERENCES

- [1] Broek D.: Elementary engineering fracture mechanics, Martinus Nijhoff Publishers, 1982, London.
- [2] Cioclov D.: Rezistenta si fiabilitate la solicitari variabile, Editura Facla, 1995, Timisoara.
- [3] Bit C.: Elementary strength of materials, Risoprint Publisher, 2005, Cluj-Napoca, Romania.
- [4] Bit C.: Puncte de vedere asupra oboselii mecanice, Editura Universității Transilvania, 2001, Brasov, Romania.