



---

25-27 October 2023

## ANALYSIS OF PARAMETERS INFLUENCING TIRE DEFORMATION IN CORRELATION WITH STATIC FORCES

---

**C.G. Sava<sup>\*1</sup>, I.A. Toflea<sup>2</sup>, D. Bragau<sup>3</sup>, G. Aldulea<sup>4</sup>**

1. Transilvania University of Braşov, Romania, cristian.sava@unitbv.ro
2. Transilvania University of Braşov, Romania, ionut.toflea@unitbv.ro
3. Transilvania University of Braşov, Romania, diana.bragau@unitbv.ro
4. Transilvania University of Braşov, Romania, george.aldulea@unitbv.ro

\*Corresponding author: cristian.sava@unitbv.ro

**Abstract:** *"For a better understanding of the world as a whole, man has conceived models. Models, when compared to reality, represent interpretations, simplifications, abstractions, and conceptualizations of reality." (citation, [1]). In the dictionary (DEX), the term 'model' is defined as: "a theoretical or material system used to indirectly study the properties and transformations of another, more complex system, with which the first system shares an analogy." (citation, DEX)*

*The design of a vehicle tire starts with minimal input data. To ensure the connection between safety, comfort, and dynamic performance, simple models are used during the initial trials. The design phase leads to defining the tire's parameters, mainly related to damping and tire stiffness. (citation, [1]).*

**Keywords:** *model, system, dynamic, parameters, damping*

### 1. INTRODUCTION

A tire represents the combination of a compressed air chamber and a tire casing. It is typically mounted on a rim, with the tire casing being made of rubber arranged in a toroidal shape [2].

Safety in a constantly changing traffic environment is of paramount importance, and the primary element that ensures it is the tire, as it establishes the connection with the contact surface [3].

The vehicle's movement is almost entirely controlled by the forces exerted on the tire by the road. Therefore, the tire's characteristics have a significant impact on maneuverability issues [4].

The essential functions of this component are [4]:

- Absorbing vehicle irregularities and bearing the normal loads.
- Generating longitudinal forces for acceleration and braking.
- Generating lateral forces for acceleration and braking.

An analysis of the state of experimental research in the field reveals that tire deformation under different pressures and various forces is highlighted using specially equipped test rigs. The deformation is measured with the help of cameras, various sensors, and compared with simulations using specialized software, particularly the finite element analysis method.

## 2. THEORETICAL CONCEPTS

During the traversal of road irregularities (e.g., speed bumps), energy is dissipated. In conditions where the energy level exceeds the limit of elastic deformation energy dissipation of the components, it is possible for them to be damaged or affected under abnormal conditions [4].

The sizing of the components (parts) of rolling systems is performed with a safety factor (typically  $K_d = 3...3.5$ ) regarding the static load on the wheel or more recently, regarding a set of loads obtained experimentally and statistically evaluated for normal operation. If an accidentally occurring load exceeds the limit value, deformations, component breakage, or mechanical influences affecting the vehicle's dynamics can occur [4]

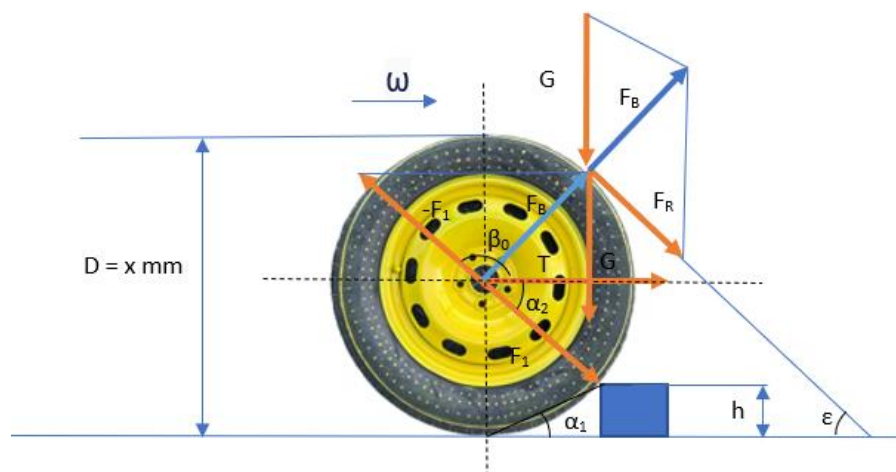

**Figure 1:** Schematic of tire interaction forces with road irregularities [5]

As an elastic element, the tire fulfills the damping function by having the capacity to store the energy of mechanical shocks that occur during interaction with the unevenness of the road surface and subsequently releasing it. Its

primary role in the damping function is to dissipate kinetic energy and reduce oscillations [1].

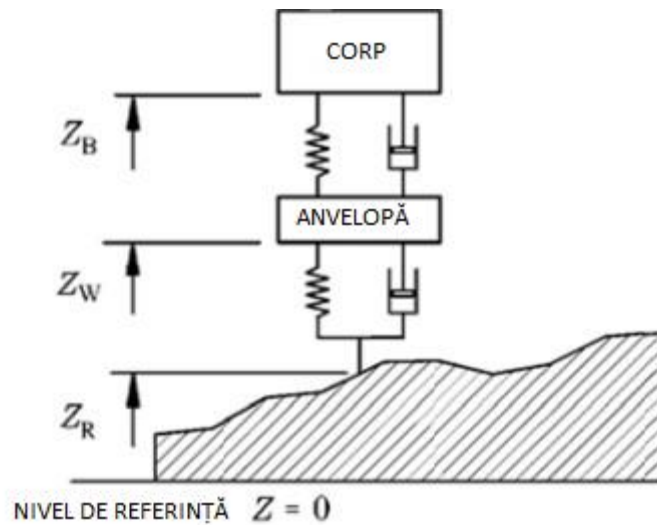

**Figure 2:** Model quarter-car [1]

A first model, considered the simplest and most practical for analyzing and improving the comfort and safety of a vehicle, is the quarter-car model (Figure 2). In this model, a quarter of the vehicle's mass is represented by both the body and the suspended components. It is supported by a tire-rim assembly through a spring and a damper [1].

### 3. TESTING SCENARIOS

To complete the full set of experimental tests, each experiment was prepared in separate stages, with each one focusing on tire deformation.

#### 3.1. Hydraulic stand

To conduct the experiment, an experimental testing stand was built. It consists of a mobile platform to which a support is mounted, allowing for the attachment of various tire-rim assemblies, actuated by a hydraulic jack.

During the tests on the stand, 36 experiments were conducted. There are three contact points between the tire and the obstacle:

- P(1) - located in the plane passing through the tire's axis of symmetry;
- P(2) - situated 5 cm away from the tire's axis of symmetry;
- P(3) - situated 10 cm away from the tire's axis of symmetry;



**Figure 3:** Experimental testing stand

### **3.2. FEM - Finite Element Analysis**

For comparing the data, the following method was employed:

Replicating the tire and curb-type obstacle in CATIA V5R20 and visualizing deformations using the finite element method by discretizing the elements, applying constraints, and imposing forces and pressures on the respective contact areas of each part.



**Figure 4:** Overview of the CAD model

To simulate in CATIA V5R21 using the Finite Element Method (FEM), the following steps were followed:

- designing a tire with the dimensions 195/65R15 in Mechanical Design - Part Design mode;
- designing an obstacle with a square profile of 100 mm x 100 mm x 350 mm in Mechanical Design - Part Design mode;
- creating the pre-impact assembly of the vehicle wheel by adding geometric constraints in Mechanical Design - Assembly Design mode;
- introducing elements in Analysis & Simulation - Generative Structural Analysis mode to perform the finite element analysis;

Testing scenarios were conducted at different levels of applied force, varying the pressure inside the tires. The results were compared to physical tests for validation.

## 4. TESTING SCENARIOS

### 4.1. Experiment on the test stand

During the testing on the hydraulic stand, two variables were taken into consideration: the pressing force and the tire's working pressure (1.7 bar and 2.0 bar).

In the initial phase, a series of experimental tests were conducted regarding the interaction of the 195/65R15-sized tire with the triangular obstacle at different pressing forces and contact points, with the tire's internal pressure set to both 2.0 bar and 1.7 bar. Pressure verification was performed using a pressure gauge before each test.



**Figure 5:** Tyre interaction with rectangular obstacle

## 4.2. Execution of finite element method (FEM) analysis

After imposing the constraints and applying the force, the "Compute" command is used to initiate the analysis. This command is repeated for various pressing forces at pressures of 1.7 bar and 2.0 bar. For a clearer view of deformations, the obstacle is hidden (Figure 6).

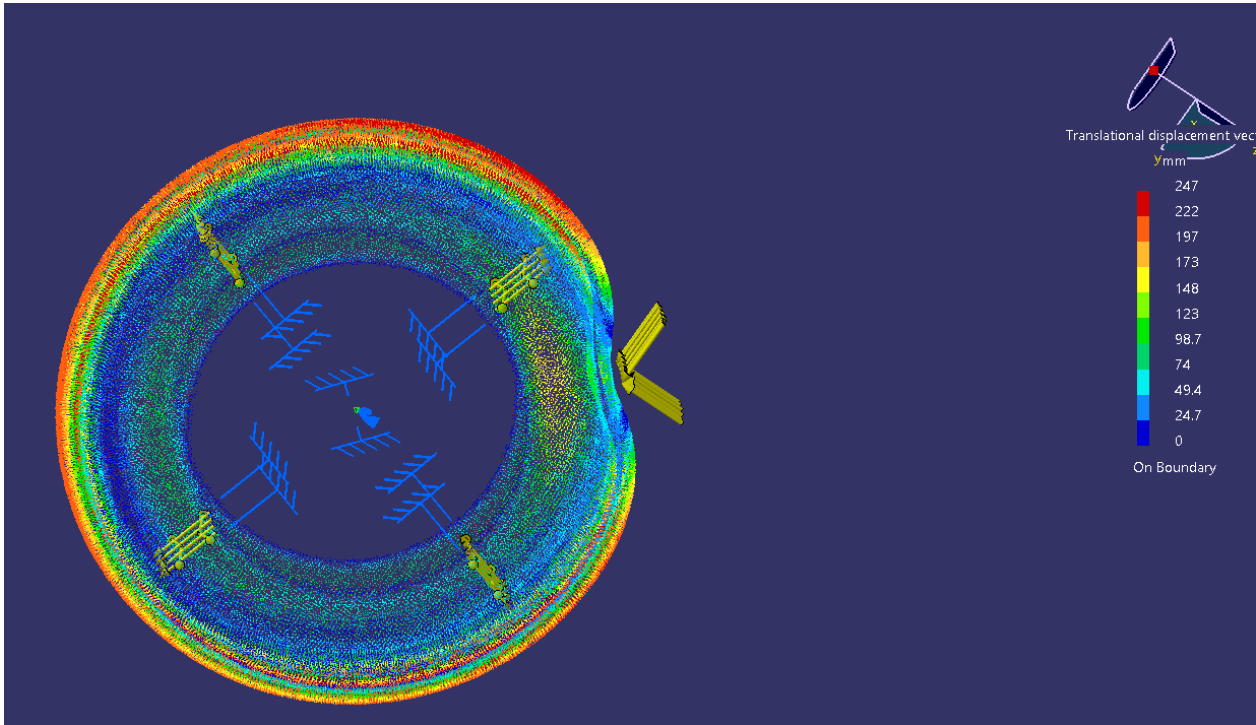

Figure 6: 3D Simulation Mode

## 5. COMPARISON OF RESULTS

Tabel1. Comparison of Static Forces by Pressure and Deformation

Types of Cases	Testing Stand	Testing Stand	FEM	FEM
Pressure [bar]	1.7	2.0	1.7	2.0
Pressing Force [N]	8646	9348	10000	10000
Deformation [mm]	79	81	94.7	88

In the comparison within Table 4.8, a difference of approximately 15.7 mm is observed between the deformations in the FEM model and the real one for  $p = 1.7$  bar, and 7 mm for 2.0 bar. These errors are attributed to the simplification of the CAD model subjected to the FEM analysis.

In the case of the graph displayed below, the difference in pressing forces for the rectangular profile at various positions relative to the tire's axis of symmetry is evident. These tests reveal that the tire's positioning in relation to the obstacle alters the forces that cause tire deformations.

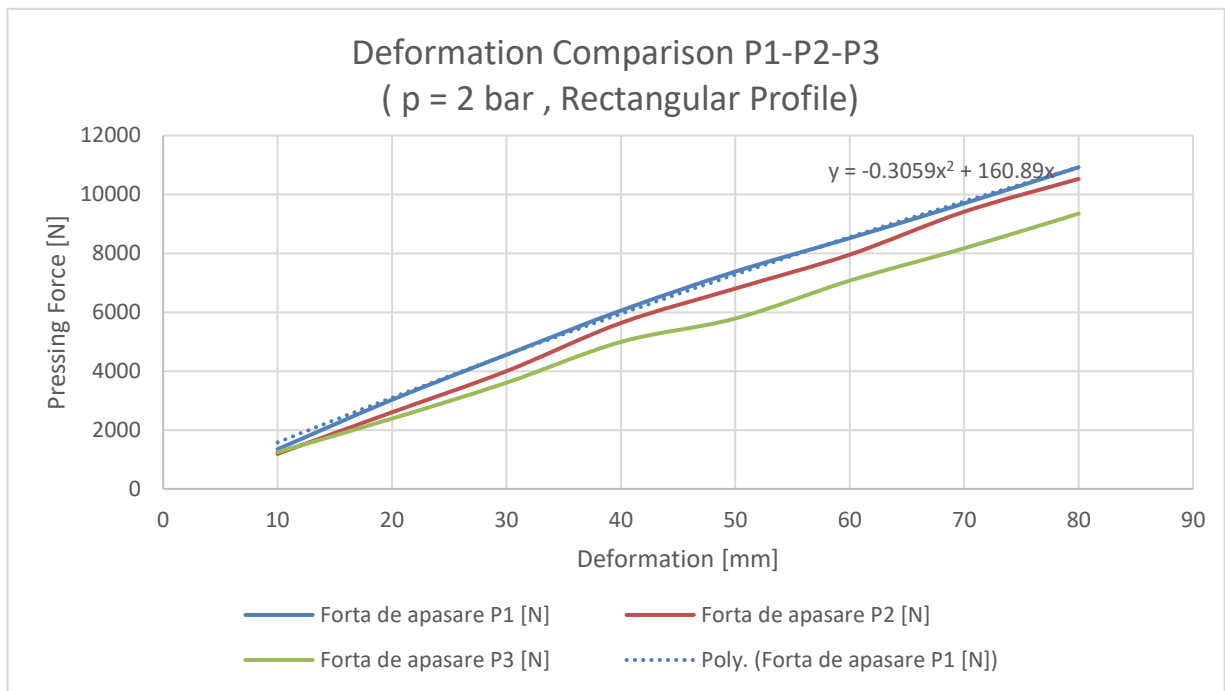

## 6. CONCLUSIONS

In the context of the experimental test, the most significant aspects include conducting the experimental trials, identifying the tire's kinematic parameters, testing using the finite element method, and conducting a comparative analysis of deformations.

The paper presents all specific test cases depending on pressure and contact point. Furthermore, a brief overview of data acquisition and processing obtained experimentally is provided. Data from the hydraulic stand were processed using Excel, resulting in second-degree polynomial equations obtained through mathematical regression. In the analysis using the FEM, the CATIA V5R21 program automatically displays deformation and stress values.

The comparison of results is carried out between the deformations in the FEM model and the real ones for pressures  $p = 1.7$  bar and 2.0 bar. The errors are attributed to the simplicity of the CAD model subjected to linear FEM analysis. Another comparison is related to the pressing forces at different positions relative to the tire's axis of symmetry.

## REFERENCES

- [1] Model Based Algorithm for the Study of the Vehicle Suspension, PREDA Ion, a 1 Automotive and Transport Department, Transilvania University of Brasov, 29 Eroilor Blvd., 500036 Brasov, Romania a pion@unitbv.ro
- [2] <https://ro.wikipedia.org/wiki/Anvelop%C4%83>
- [3] Calculul si constructia automobilelor – M.Untaru, GH. Fratila si altii. – Editura didactica si pedagogica Bucuresti 1982
- [4] Dixon, John C. Tires, Suspension and Handling, 2nd Rev. ed. SAE International, Warrendale, PA, USA, 1996. ISBN 978-1-56091-831-8
- [5] Radial Tire Conditions Analysis guide – A Comprehensive Review of Tread Wear And Tire Conditions – The Maintenance Conditions