



DETERMINATION OF COEFFICIENT OF THERMAL CONDUCTIVITY ON GLASS FIBERS-REINFORCED POLYMER MATRIX COMPOSITES

Gheorghe Vasile¹, Bejan Costel², Sandu Venetia³, Lihtetchi Ioan⁴ Eugenia Secară

¹ INAR S.A., Brasov, ROMANIA, ghesile@yahoo.com

² INAR S.A., Brasov, ROMANIA, cvbejan@yahoo.com

³ "Transilvania" University, Brasov, ROMANIA, sandu@unitbv.ro

⁴ "Transilvania" University, Brasov, ROMANIA, lihtetchi@unitbv.ro

Abstract: This paper presents the determination of the coefficient of thermal conductivity for composite materials reinforced with fiberglass. The sheets tested on the stand were cut from a sheet made from 15 layers of fiberglass fabric.

Keywords: coefficient of thermal conductivity, composite materials, fiberglass fabric.

1. INTRODUCTION

Thermal conductivity coefficient characterized the material properties to lead the heat flow. The coefficient of thermal conductivity is a physical constant that depends on the shape of the material, on the nature, temperature, aggregate state and it is determined experimentally.

The coefficient of thermal conductivity is numerically equal to the stationary conductive heat flow, passing through a unit area of a sheet of uniform thickness, when the difference of temperature between the outer surfaces is equal to unity. So:

$$\lambda = \frac{q \cdot \delta}{\Delta t} \left[\frac{\text{W}}{\text{mK}} \right]$$

(1)

Experimental determination of these coefficients involves experimental measuring of q , δ and Δt .

2. TEST BENCH

The test bench for determination of the thermal conductivity coefficient of insulating materials with flat shape, homogeneous, microporous, with fibers or of particles is designed by Dr. Bock. The testing area is $\lambda = 0,029...1,977 \text{ W}/(\text{mK})$.

Schematic diagram of this system is shown in Figure 1.

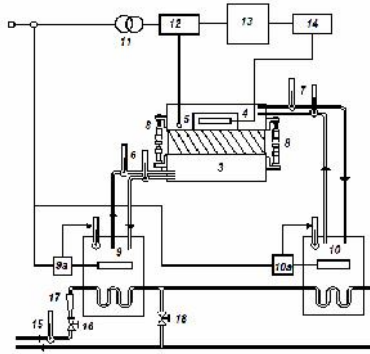

Figure 1: Schematic diagram of the stand for determination thermal conductivity coefficient

Determination of the thermal conductivity coefficient is based on the heating plate with one test body. Sample material (1) is placed between two flat metal plates, the upper (2) with a higher constant temperature, called heaters, equipped with an electrical resistance. The lower plate (3) with a lower constant temperature - cold called, that gives warmth. Hot plate is covered by another protective plate (4) to prevent loss of heat from the hot plate.

Protection plate temperature is kept constant through its connection to the heating circuit of the thermostat (10) with thermoregulator (10a). Constant temperature of the cold plate is achieved by the cooling circuit of the thermostat (9) with its thermoregulator (9a).

Cooling water circulating through the coil thermostats, in whose routes lie thermometer (15) and rotameters (17), reduce the thermal inertia of the water in the thermostatic hot plate and take the heat transferred to the cold plate and to the its thermostat.

With thermometers (7) determine the mean temperature of thermal agent in protection plate. Thermometers (6) determine the mean temperature of thermal agent in cold plate. With these thermometers can calculate the temperature drop of the sample.

In electrical resistance circuit is interposed a rheostat with twelve positions (14). Maintenance a constant temperature over the entire surface of the top plate in contact with the sample of material is performed by the thermocouple (5) which is connected to the millivoltmeter (12).

Consumption of electrical energy give to the heating plate are recorded by an electric meter (13) located in the electrical resistance circuit. In the power supply circuit is located a variable transformer with seven positions (11).

During the measurement, metal plates are surrounded by a protective box, which is designed to reduce heat loss to the outside.

With the help of four micrometers (8), fixed to the top plate, measure the thickness of the sample material.

3. PREPARATION OF MATERIAL SAMPLES

Samples of the materials are in the form of square or circular plate with plane and parallel surfaces, with an edge length or a diameter between 200 mm and 250 mm. The thickness of the samples are between 3 and 70 mm.

In this paper test sheets were cut from a sheet made from 15 layers of fiber-glass fabric (Figure 2). Plates size is 250 x 250 mm.

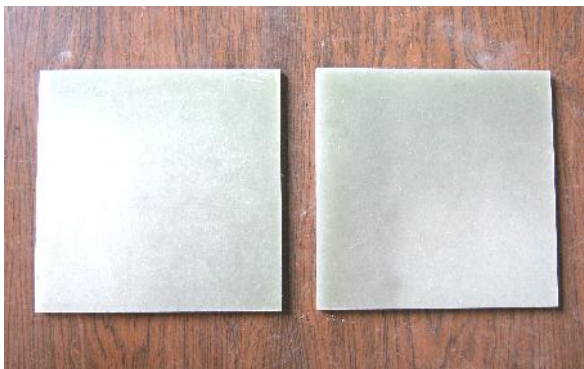

Figure 2: The plates used for determining the thermal conductivity coefficient

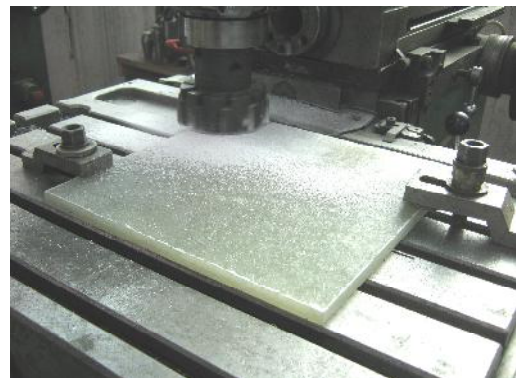

Figure 3: Milling fiberglass plates

Because the plate was free molded in an open mold, its thickness was not constant and one of its surfaces wasn't flat. For this reason the plates were made subject to a milling processing (Figure 3). By milling, obtain an uniform thickness of plates and both sides have become flat. In Figures 4 and 5 are shown the face and the edge of a plate which has been processed.

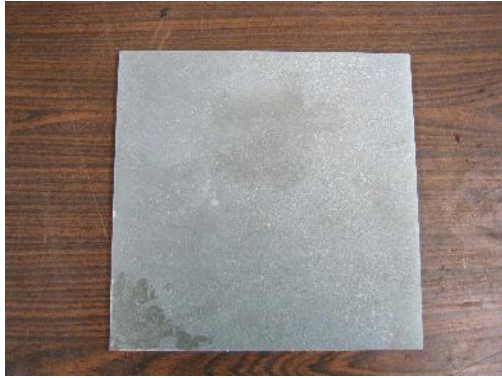

Figure 4: Milling face of fiberglass plate



Figure 5: Edge of fiberglass plate

4. MEASUREMENTS

After the system is entering in steady state operation, following determinations are made from 0.25 to 0.25 hours, which fall in the worksheet:

- hours and minutes indicated by the clock;
- indication of electricity meter;
- thermal agent temperature reading on thermometers (7) located at the entrance and to the exit of the upper plate (tci, tce) and to the thermometers (6) of the bottom plate (tri, tre);
- room temperature;
- cooling water temperature;
- thickness of the sample is measured at the end of the experiment with these four micrometers.

Data reading by measurement instruments and data calculated are recorded in a single worksheet. To each plate was carried out a worksheet. The worksheets for the two parts are attached down (Table 1 and Table 2).

5. ACKNOWLEDGEMENT



PROGRAMUL OPERAȚIONAL SECTORIAL „CREȘTEREA COMPETITIVITĂȚII ECONOMICE”
 „Investiții pentru viitorul dumneavoastră”

Proiect: Dezvoltarea de componente din materiale compozite avansate cu aplicații în industria auto civilă și militară. Proiect cofinanțat de Uniunea Europeană prin Fondul European de Dezvoltare Regională

REFERENCES

- [1] Badea A., Necula H., Stan M., Ionescu L., Blaga P., Darie G., Echipamente și instalații termice, Editura Tehnică, București, 2003.
- [2] Kreith F. Handbook of thermal engineering, CRC, Boca Raton, Florida, 2000.
- [3]. Pop M.G., Leca A., Prisecaru I., Neaga C., Zidaru G., Mușatescu V., Isbășoiu E.C. Îndrumar. Tabele, nomograme și formule termotehnice, Editura Tehnică, București, 1987.

Table 1. Thermal test result

Specimen no.	1	Material	Plastics			Date	
Read no..	1	2	3	4	5	6	...13
Time							
Room temperature TR [°]	20						
Meter reading E [kW]	556,7793	556,7919	556,8036	556,8142	556,8241	556,833	
Entering heating plate protective tci [°]	31,58	31,72	31,62	31,65	31,71	31,72	
Output heating plate protective tce [°]	31,55	31,58	31,53	31,52	31,6	31,6	
Entrance cooling plate tri [°]	22,24	22,65	23,05	23,4	23,62	23,78	
Output cooling plate tre [°]	22,05	22,42	22,84	23,19	23,35	23,55	
Power stage	9						
ΔE [kW]	0,0126	0,0117	0,0106	0,0099	0,0089	0	
$\Delta \zeta$ [h]	0,25	0,25	0,25	0,25	0,25		
$\Delta E/\Delta \zeta$	0,0504	0,0468	0,0424	0,0396	0,0356	0	

Micrometers	Measurement	Error	Corrected value
$\delta 1$ [mm]	10,31	0,01	10,3
$\delta 2$ [mm]	10,55	0,01	10,54
$\delta 3$ [mm]	10,53	0,01	10,52
$\delta 4$ [mm]	10,48	0,01	10,47
$\Sigma \delta 1-4$ [mm]			41,83
$\Sigma \delta 1-4/4$ [mm]			10,4575
Δ [kcal/(h*grad)]			0,133835907834897

Table 2: Thermal test results

Specimen no.	2	Material	Plastics			Date								
Read no..	1	2	3	4	5	6	7	8	9	10	11	12	13	
Time														
Room temperature TR [°]	20													
Meter reading E [kW]	555,9353	556,9464	556,9558	556,9556	556,9747	556,8833	556,8975	556,993	557,0055	557,0725	557,0181	557,0242	557,0794	
Entering heating plate protective tci [°]	31,7	31,65	31,62	31,8	31,63	31,61	31,6	31,6	31,75	31,65	31,73	31,58	31,7	
Output heating plate protective tce [°]	31,58	31,55	31,59	31,61	31,55	31,53	31,51	31,52	31,61	31,59	31,64	31,51	31,61	
Entrance cooling plate tri [°]	22,2	22,48	22,7	22,9	23	23,2	23,4	23,57	23,71	23,88	24,07	24,22	24,2	
Output cooling plate tre [°]	21,96	22,25	22,45	22,64	22,7	22,91	23,16	23,32	23,5	23,58	23,73	23,86	23,9	
Power stage	9													
ΔE [kW]	0,0111	0,0104	0,0088	0,0097	0,0086	0,0083	0,0074	0,0065	0,0077	0,0056	0,0061	0,0052	0	
$\Delta \zeta$ [h]	0,25	0,25	0,25	0,25	0,25	0,25	0,25	0,25	0,25	0,25	0,25	0,25	0,25	
$\Delta E/\Delta \zeta$	0,0444	0,0416	0,0352	0,0391	0,0344	0,0332	0,0295	0,026	0,0308	0,0224	0,0247	0,0208	0	
Micrometers	Measurement	Error	Corrected value											
$\delta 1$ [mm]	9,52	0,01	9,51											
$\delta 2$ [mm]	9,7	0,01	9,69											
$\delta 3$ [mm]	9,53	0,01	9,52											
$\delta 4$ [mm]	9,23	0,01	9,22											
$\Sigma \delta 1-4$ [mm]			38,24											
$\Sigma \delta 1-4/4$ [mm]			9,56											
Δ [kcal/(h*grad)]			0,0911042736053292											