



5th International Conference
"Computational Mechanics and Virtual Engineering "
COMEC 2013
24- 25 October 2013, Braşov, Romania

COMPLEX CONTINUOUS-LUMPED MODEL FOR SIMULATION OF VIBRATORY COMPACTION PROCESS

Gigel Florin Capatana

"Dunarea de Jos" University of Galati, Engineering Faculty in Braila,
Research Center for Mechanics of Machines and Technological Equipments
Calea Calarasilor 29, 810017 Braila, Romania

Abstract: *The main goal of this study consists by a complex lumped-continuous model of terrain compaction and related machine-terrain interaction approaches. In this paper, the author tries to use a new method to evaluate and analyze the interaction between the vibratory drum and the terrain. The analysis is rheological approached, with a predominantly dynamic behaviour, in order to reveal the compatibility of the working body performances with the characteristics of the terrain. The study has made in the conditions of complex rheological approaches of a direct influence area of vibration on compacted domain material. Based on classical elastic and dissipative models the author was build a multiple layer continuous-lumped system that is able to simulates the continuous phenomenon during each layer taking into account discrete linkages between adjacent layers.*

Keywords: *vibratory compaction technology, continuous-lumped model, rheological evaluation, energy transf. maximization*

1. INTRODUCTION

The basic idea supposes that it has to have assured the energy transfer maximization in the interaction between the two main components of the system. The model must have permanent and continuous adjustments of the material characteristics so it can be evaluated the technological capability. The fulfilling of these objectives will be providing by using a complex model with both distributed and concentrated elements, which is able to supply the rheology of elastic, dissipative and plastic types.

The previous remarks of the author studies frame the idea that the harmonization of the basic parameters of the model with the experimental values can lead to structural and functional optimizations of the entire technological system. Virtual simulation model of vibratory roller-field system behavior must take into account both the characteristics of the two basic elements - working body and terrain respectively, and the interaction between them. The basic element of this analysis is the rheological model that is able to simulate the phenomena occurring at the interface between roller and terrain.

In Figure 1 are presenting four rheological models based on elastic and dissipative behavior, capable of simulating the behavior of the terrain interacting with the working body of vibratory compaction equipment.

These two models are elastic-plastic type without consolidation (a) and with the consolidation (b). Either of the two rheological models can model the specific settlement of material types, but the consolidation phenomenon has simulated only when those two components has installed in parallel configuration (see Figure 1.b).

Taking account the theoretical considerations of earlier chapters of the paper it is proposed that the initial version for an application development intended to simulations on the virtual model of complex system behavior roller - terrain a dissipative elastic model of the type shown in Figure 1 (b).

The reasoning behind this approach consists of the following aspects:

- This model is simple by the point of structural view and functionally, providing an easy way of implementation within an numerical simulator;
- The proposed model is able to highlight the feature of strengthening the materials;
- The absence of dissipative components by the viscous type, which although in some cases may be a weakness of the model, remove restrictions relating to the application speed of external loads and thus gain a general model relative to the type and method of excitation.

The constitutive equation of elastic-plastic model in Figure 2 is

$$F_{ex} = \begin{cases} k x(t) + F_{fr} \operatorname{sign}\left(\frac{dx}{dt}\right) & \text{pentru } F_{externa} > F_{fr} \\ 0 & \text{pentru } F_{externa} \leq F_{fr} \end{cases} \quad (1)$$

where k is the stiffness of the elastic component F_e of the model, F_{fr} is friction force of the specific plastic component F_p and sign signifies *signum* function. In this model, the friction force is the Coulomb type that is a constant evolution with the speed. The behaviors of elastic-plastic model consolidation (see Fig.2) under external load σ have been grouping in Table 1.

This model is nonlinear because of presences element that simulates Coulomb friction type. The solving of this type of mathematical model involves the use of specific numerical methods for approximating the final solution or model implementation within an software package specializing in computerized math. This second option is preferable because it assumes the existence of computational routines optimized and adapted to a wide range of types of mathematical models. Thus is eliminated verification stage of mathematical model relating to how and accuracy that evaluation of the final solution.

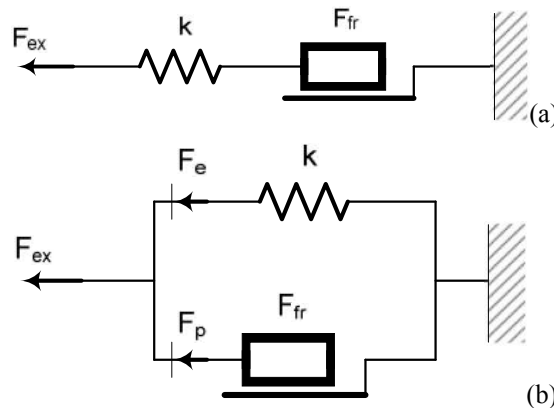

Figure 1: Rheological models for simulation in the field interacting with vibratory compact equipment; a) elastic and plastic model without consolidation; (b) elastic and plastic model with consolidation.

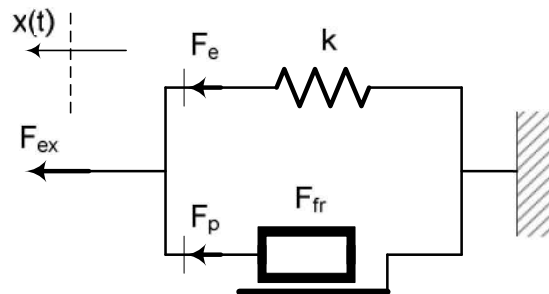

Figure 2: Elastic and plastic model for simulation analysis terrain behavior in interaction with vibratory compactor equipment

Table 1. Numerical behaviour of working of elasto-plastic model with consolidation

INTERNAL CONDITIONING		EXTERNAL CONDITIONING	
		$\sigma \leq F_{ex}$	$\sigma > F_{ex}$
$F_e \leq F_p$	solution	$x_i = x_{i-1}$	$x_i = \sigma / k$
	state	<i>null deformation</i>	<i>elasto-plastic deformation</i>
$F_e > F_p$	solution	$x_i = F_p / k$	$x_i = \sigma / k$
	state	<i>elastic recovery</i>	<i>elasto-plastic deformation</i>

Therefore, to solve the proposed model has adopted to achieve a variant of mathematical applications in computerized environment Matlab ©. From the vast library of functions, routines and specialized modules

available computing solution implementation in Matlab was chosen rheological model a type application Simulink © - SimMechanics ©. The main advantages of this approach have given by the following:

- 1) the module of programming is of graphical type, removing in totality the writing stage orders related to the application;
- 2) the existence within the Simulink © - SimMechanics © of functional elements ready programmed (verified and optimized) that perform different tasks thus in order to reduce the use of o the application programming specific elements and the establishment of interconnections between them.

2. NUMERICAL SIMULATION

In Figure 3 is presented the basic scheme of the application for the analysis of elastic-plastic model behavior with consolidation (see Fig. 2) subjected to external actions harmonic type.

It makes mention that the type of excitation may change depending on the requirements analysis problem by simply replacing the corresponding element of the scheme (in the case presented "Sine Wave" - Harmonic signal generator) and setting the working parameters.

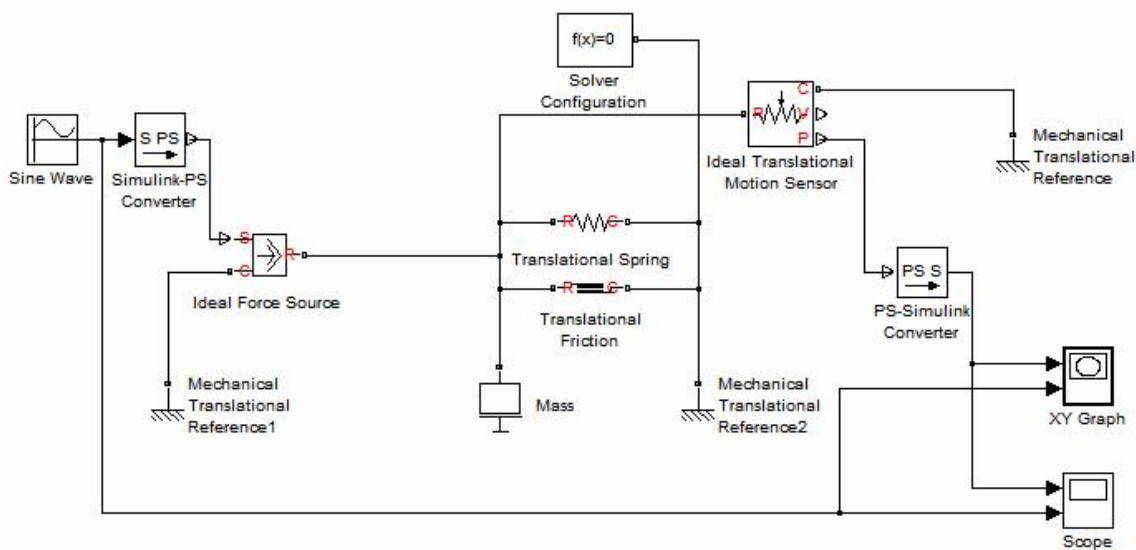

Figure 3: The Basic scheme of the virtual instrument model analysis of elastio-plastic behavior of the harmonic actions

Constituent elements of the diagram shown in Figure 3 are characteristic of applications in Simulink © - SimMechanics ©. Per categories, these are:

1. the elements of signal generation (Sine Wave),
2. takeover elements, Graphic presentation and plotting aid of the results (XY Graph, Scope),
3. signal conversion elements from Simulink in SimMechanics (Simulink-PS Converter) and backwards (PS-Simulink Converter),
4. the excitation elements (Ideal Force Source),
5. transducers elements for retrieving information from different points of interest in the analyzed scheme (Ideal Translational Motion Sensor),
6. the basic elements of the application what simulates the rheological behavior of the model proposed (Translational Spring - linear elastic element, Translational Friction - dissipative friction element, Mass - element type moving mass of translational, Mechanical Translational Reference - reference point who materialized fixed link to the global coordinate system),
7. the block for setting parameters needed of numeric solve to specific mathematical model of the set of equations (Solver Configuration).

In general, there are two major categories of functional blocks, namely: those that contain the basic elements and those containing auxiliary elements necessary assembly and execution of the application. The basic elements are those that ensure the implementation of the characteristics required for the desired pattern.

In the case presented in Figure 3 these elements are:

- ❖ the linear elastic element - this implements a constitutive Hooke law what entails a linear dependence between deformation element and forces applied at its extremities; the element require initial determination of stiffness coefficient and unit of measure for this.

- ❖ the dissipative friction element - this is a nonlinear element and implementation available in Simulink © - © SimMechanics allows programming of complex and general laws, which are contain data regarding the static friction, dynamic and viscous. General law is of the form

$$F = \left[F_C + (F_{brk} - F_C) e^{-c_v |v|} \right] \text{sign}(v) + f_v v \quad (2)$$

where notations have the following meanings

- F is the total friction force, simulated the respective element,
- F_C is the Coulomb friction force which involves a constant value independent of external load application speed,
- F_{brk} is the force of static friction (at detachment) - this value is a threshold value and is valid for null speed load application
- c_v is a coefficient of proportionality corresponding model of Stribeck friction law which requires a emphasized decline at the value of the friction force depending on the load application speed
- $v = v_R - v_C$ is the relative velocity between the two points of connection of the model (R , respectively C , on the diagram of Fig. 3)
- f_v is the viscous friction coefficient, which defines the proportionality between the friction force and external load application velocity.

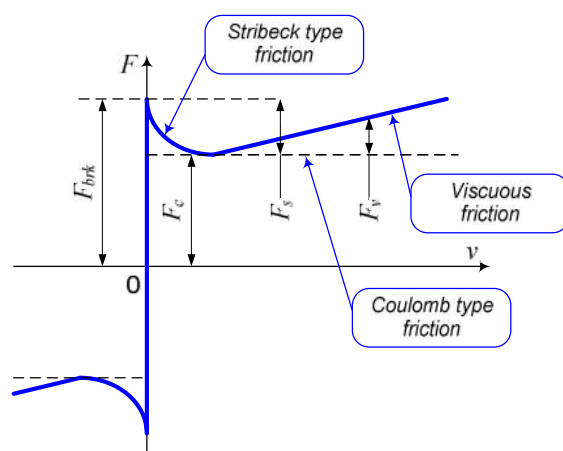

Figure 4: The complex model of the friction force-theoretic version (implemented in Matlab-SimMechanics© software)

In Figure 4 is presented the corresponding graphic variation law of the friction force - equation (2). The diagram in figure shows the three characteristic areas described in the previous paragraph. It can be noticed also that for null velocity values the characteristic is discontinuous. this fact is due to the specific threshold value of static friction. in this case the approximation is purely theoretically and has some major inconvenience. Among these are mentioned the following:

- special problems occur in the numerical solving of the model due to the existence of the discontinuity point
- the respective simplification is not a realistic approach in the sense that the phenomenon of discontinuous friction model does not have cover into reality and mechanical contact with the mass distributed model does not ensure the instantaneous increase of the friction force developed.

In the specialty literature there are many types of models of the phenomenon of friction without the discontinuities. In the module implemented in Simulink © - © SimMechanics has adopted a simple model of the friction force that ensures continuity depending on the relative speed of application of the external request. Mathematics formulation (3) is the characteristic equation of this model. In Figure 5 is shown the diagram corresponding to this type of continuously model.

$$F = \begin{cases} \left[F_C + (F_{brk} - F_C) e^{-c_v |v|} \right] \text{sign}(v) + f_v v & \text{pentru } |v| \geq v_{th} \\ v \frac{f_v v_{th} + \left[F_C + (F_{brk} - F_C) e^{-c_v v_{th}} \right]}{v_{th}} & \text{pentru } |v| < v_{th} \end{cases} \quad (3)$$

The novelty element compared with the previous model - equation (2) and Fig. 4 is represent elimination of origin by introducing a discontinuity finite and very narrow areas, near the origin, it is considered that the friction force is proportional to speed.

3. ACHIEVED RESULTS. DISCUSSIONS

For modeling the interaction between the roller and terrain in within the numerical applications presented in Figure 3, was adopted a type of harmonic excitation force. Simulation of static component of the total force terrain press was used additive constant at the expression dynamic component. Thus, the approximation relationship of total excitation force is

$$F_{ex}(t) = F_{st} + F_{din}(t) = F_{st} + A_o \sin(\omega t + \varphi) \quad (4)$$

where F_{st} is the static component, F_{din} is the dynamic component, A_o is the amplitude of the dynamic component, iar also ω si end φ are the pulsation, respectively the phase shift at the harmonic excitation. The simulation of continue pressing on the soil whatever their dynamic working conditions impose as static component value to be superior to amplitude peak to peak of the dynamic component.

For the case presented in the paper were adopted the following excitation source parameter values $F_{st} = 26$ N, $A_o = 25$ N, $\omega = 2$ rad/s, $\varphi = 0^\circ$. The corresponding diagram is given in Figure 5. The considered system response at harmonic excitation in Figure 5 is shown in Figure 6. In this figure are shown both the total deformation terrain diagram (a) and a detail of the area compaction (b).

In the diagram from Figure 6 are marked the two work areas of interest, namely: the area elastic-plastic which the material is compacted and respectively the elastic area in which the material takes the form of external dynamic loads exclusively of some elastic deformations in successive cycles loading - unloading without the present of remanent deformations. Basically this area corresponds to both the consolidation regime post-compaction and effective regime of exploitation. With ε_p was labeled total plastic deformation (consolidation is C_c) and the elastic deformation with ε_e is produced by dynamic loads disturbing.

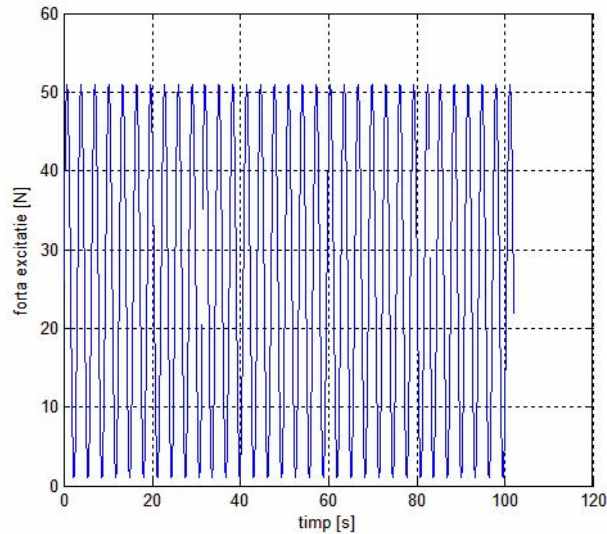

Figure 5. Excitation signal - harmonic function

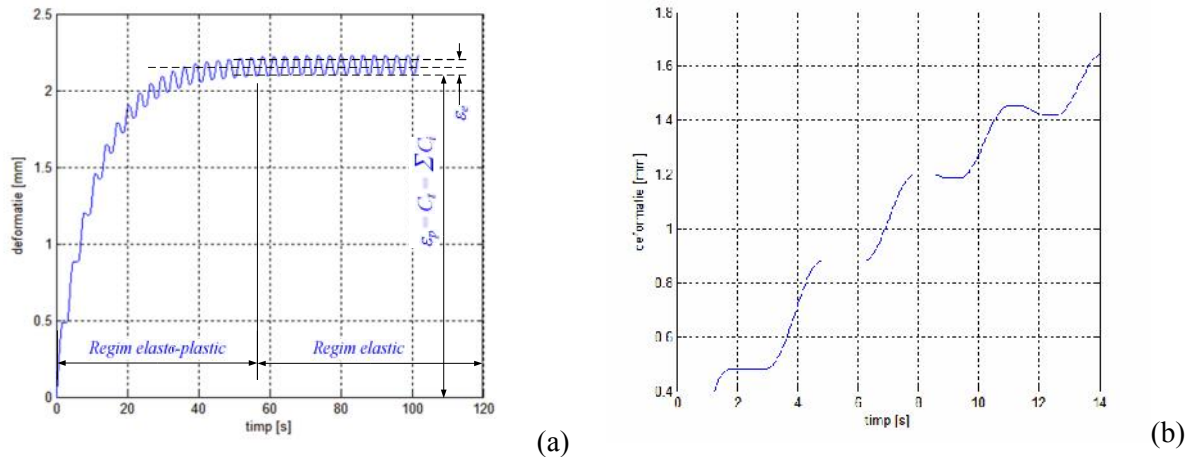

Figure 6. The system response at harmonic excitation function from Figure 5.

(a) Highlighting the working regimes and essential parameters of vibrating compaction process during about 100 s; (b) detail.

4. CONCLUSIONS

The proposed model for the analysis of system behavior vibratory roller - terrain started from principal hypothesis according to which for the development of complex virtual instrument required for depth analysis of the proposed issues is absolute necessary to give a first numerical approximation to be able to simulate the essence of the phenomenon of interaction between machine and terrain.

For achieving a complete model for the analysis of system behavior vibratory roller - terrain is necessary a model for basis (a nucleus, a first approximation of the model) which has the following characteristics:

- to be simple enough to be easily understood and solved;
- to be sufficiently complex to simulate the essential phenomena to be analyzed.

The aim of this study was to determine and verify of such a basis model of that can simulate the compaction process of the terrain under the action of dynamic loads produced by a vibrating roller compactor.

Analyzing the results presented earlier in the paper and considering the hypothesis stated above, one can conclude that the initial purpose was reached and elastic-plastic model with consolidation is the best solution to simulate the compaction process. The achieved application highlights all the important aspects of the interaction roller vibrator with the terrain that must be compacted. The application will have developed further by including aspects of the nonlinear behavior of the terrain, the change in real-time excitation parameters and influence of the state on the effective range of adjacent areas analyzed.

REFERENCES

- [1] Bratu, P., Vibratiile sistemelor elastice, Ed. Tehnica, Bucharest, 2000
- [2] Bratu, P. si altii, Tehnologii si Utilaje pentru Executarea, Intretinerea si Reabilitarea Suprastructurilor de Drumuri, Ed.Impuls, Bucharest, 2004
- [3] Bratu P., Mecanica teoretica, Ed.Impuls, Bucharest, 2006
- [4] Adam D., Korf F., Theoretical analysis of dynamically loaded soils, European Workshop: Compaction of soils and granular materials, ETC 11 of ISSMGE, Paris, Franta, 2000
- [5] Nastac, S., Debeleac, C., "On Multipoint Spectral Analysis in Dynamic Sources Behaviour Identification and Evaluation", WSEAS Transactions on Systems, Issue 10, Vol.7, 2008, pp. 996-1005
- [6] Nastac, S., Leopa, A., "Comparative Analysis of Visco-elastic Models with Variable Parameters", Analele Universitatii "Eftimie Murgu" Resita, Anul XVII, Nr. 1, 2010, 227-232
- [7] Oproescu, Gh., Debeleac, C., Leopa, A., Nastac, S., "On the Rheological Behaviour of the Soil in the Artificial Compacting Process", The Annals of "Dunarea de Jos" University of Galati, Fascicle XIV, 2008, pp. 63-70
- [8] Nastac, S., "Model reologic pentru analiza stării de tensiuni și deformații în solurile supuse procesului tehnologic de compactare", Al III-lea Colocviu Național Tehnic Interdisciplinar, Facultatea de Inginerie Brăila, 1997, 181-184
- [9] Kolumban, V., Contributii la optimizarea performantelor masinilor de compactare prin vibrare, Teza de doctorat, Universitatea „Dunarea de Jos” din Galati, 2000