

DATA ACQUISITION SYSTEM BASED ON GPS TECHNOLOGY, FOR VEHICLE DYNAMICS ANALYSIS

Dinu Covaciu, Ion Preda, Gheorghe Ciolan, Ovidiu-Vasile Cămpian

Transilvania University of Braşov, Romania

KEYWORDS - vehicle dynamics, data acquisition, GPS, velocity, acceleration

ABSTRACT - The GPS devices are well known and used by many people, especially for navigation. These are commercial GPS devices, which can be found at decent prices. Professional devices also exist for geodesic applications, and even for dynamic data acquisition. These are much more precise devices, but also very expensive.

This paper presents a complete acquisition system developed by the authors, using a high performance GPS device, available on the market, a portable mini-computer (UMPC) and dedicated software. The GPS sensor is one oriented to OEM users, for machine operation and guiding and agricultural applications. The sensitivity is very high and the registration rate is 5 Hz. It is connected to a computer through serial interface.

The software application developed for this system takes the information from the GPS sensor using special sentences defined by the NMEA messages standard. Information about position, velocity and acceleration are displayed in real time on the computer display and all useful data acquired are saved in a text file. These data are imported then in a special CAD application, for post-processing. The system was used in various studies regarding vehicle dynamics or efficiency and traffic or noise analysis. Some diagrams and reports obtained after post-processing are also presented in the paper.

INTRODUCTION

The GPS technology becomes more spread on the commercial market. Various applications are offered, especially for navigation and for recording of the route travelled by different vehicles or pedestrians [4]. Beside the existent applications, mainly for on-board navigation systems, new others start emerging. This tendency is supported by the down scaling of the electronic devices, price decrease and performance augmentation of GPS receivers [5]. Two important advantages of the GPS receivers consist in the existence of a very precise and universal time information and the existence of three-dimensional position data that can be derived to obtain other useful information as height, slope, velocity and acceleration.

The GPS receivers are able to store data in their internal memory (like SD cards or CompactFlash), or can also send data to other devices through RS232 or USB interfaces, using a transfer protocol. A well known protocol for transferring GPS data is defined in the NMEA 0183 standard [7]. NMEA 0183 defines the requirements for the electric signal and for the data transfer protocol, and also the format of specific sentences for a 4800 bauds serial data bus. For higher rates it was defined an extension named NMEA 0183-HS (*High Speed*).

A NMEA sequence consists in a string containing a type identifier and more data fields, comma separated. The type identifier is used to establish the type and format of the sequence. The number and lengths of fields depend by the sequence type.

Each NMEA sequence starts with a \$ character, like in the examples below:

```
$GPGGA,123519,4807.038,N,01131.000,E,1,08,0.9,545.4,M,46.9,M,,*47
$GPGSA,A,3,04,05,,09,12,,,24,,,,,2.5,1.3,2.1*39
$GPRMC,123519,A,4807.038,N,01131.000,E,022.4,084.4,230394,003.1,W*6A
```

Data taken from GPS include the geographic coordinates (longitude and altitude) and the altitude, used to position the receiver on the earth surface. The geographic coordinates must be converted in rectangular coordinates (x, y), in order to use them in the automotive kinematics studies. This operation can be done using dedicated software.

THE GPS RECEIVER

GPS 18x-5Hz (*fig. 1*) is a GPS sensor used especially for machines operation, guiding and various agricultural applications, where very precise positioning and velocity information are required [8].



Fig.1 – GPS 18x-5Hz receiver

Some of the technical characteristics of the sensor are given below:

- diameter / height / weight: 61mm / 19.5 mm / 165 g;
- supply voltage: 4.0 - 5.5 Vcc;
- sensitivity: -185 dBm;
- acquisition rate: 5 Hz;
- interfaces: RS232 with default rate 19200.

The necessary time for the signal to travel from each satellite to receiver is affected by the atmospheric condition and this affects the precision obtained without additional corrections. The influence of atmospheric condition and obstacles may be revealed by recording the position of a stationary receiver [2, 3]. The results measured with a stationary GPS 18x-5Hz receiver are shown in *fig. 2*. Both records are taken in the same position, for 30 seconds and 100 seconds, respectively. The number of satellites was 8 for the first measurement, and 7-8 for the second measurement. The accuracy reported by the receiver through NMEA sequences (HDOP – *Horizontal Dilution Of Precision*) was 0.9 – 1.2, values which generally indicate a good accuracy. According to *figure 2*, with these measurements it was obtained a positioning precision of 0.342 - 0.475 meters.

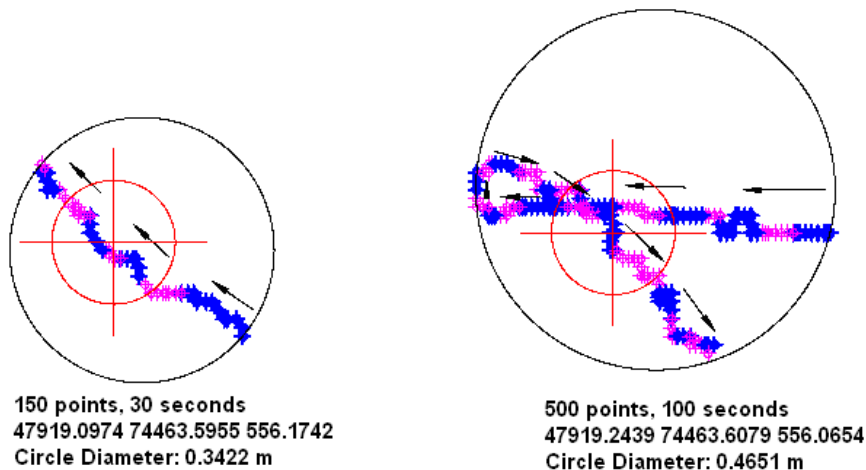

Fig. 2 - Measurements with the GPS receiver stationary

Some measurements realised simultaneously with GPS 18x-5Hz and another GPS receiver show the advantages of using the 5 Hz receiver. In figure 3 are presented the results obtained with GPS 18x-5Hz (in red) and GPSmap 60CSx (in blue), a commercial good-quality GPS device.

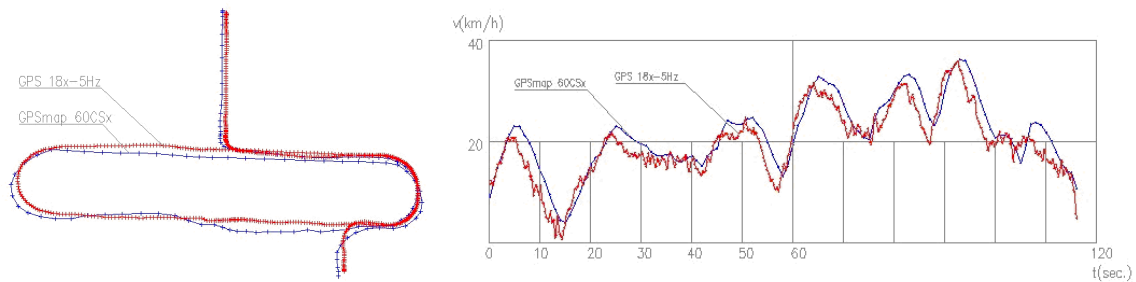

Fig. 3 - Track recorded with two different devices, and speed/time diagram for both records

In the left side of *figure 3* is represented the track recorded with both devices, and in the right side is represented the speed versus time diagram. It can be seen that the GPS 18x-5Hz device is more sensitive and the recorded data are more accurate. The speed is calculated in both cases using the position and time information and is not filtered.

DATA ACQUISITION SYSTEM

Based on the Garmin GPS 18x-5Hz receiver [8] it was developed an original tool for vehicle dynamic behaviour analysis (called *DS-5*) [2, 5]. The system has two main components: hardware and software. The hardware part consists in the GPS receiver, a minicomputer (like a tablet PC) and the connecting interface, usually a RS232-USB adapter. The software part is a stand-alone computer program developed in Delphi programming language. The program is used for data acquisition and for storing that data as text files on the computer.

HARDWARE

The system is composed by the GPS receiver, the interface and the minicomputer. Depending by the minicomputer used sometimes may be necessary to use also an inverter, for plugging the computer to the vehicle 12 V outlet.

The GPS receiver is the Garmin GPS 18x-5Hz device. This device has a connecting cable terminated as bare wires and it has to be connected to a RS232 interface. The connection diagram is shown in *figure 4* [8].

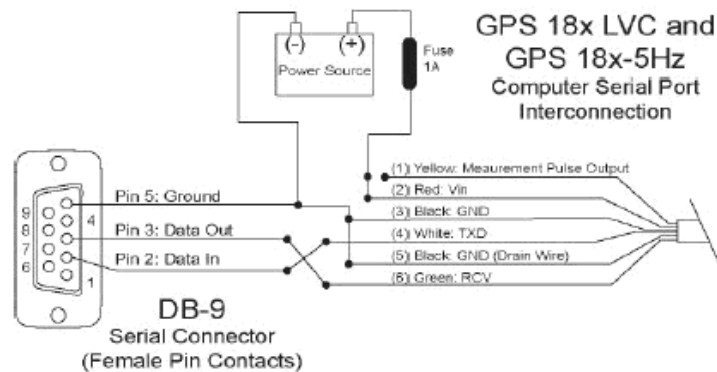

Fig. 4 – GPS 18x connection diagram [8]

The power supply is not the vehicle's cigarette lighter outlet (however, this can be used as power supply for the computer). Instead, it is used one of the computer USB connectors as a 5 volts power source. The advantage of using the computer's USB interface is that the computer battery is also a power back-up for the GPS receiver. Since the minicomputers (tablets PCs) does not have a RS232 interface, it must be used an adapter cable between the computer USB connector and the device connector.

SOFTWARE

The software component of the DS-5 system is a computer program developed in Delphi programming language. The program receives data from the GPS device as NMEA sequences. The NMEA codes are interpreted and the necessary data are extracted, like time, speed and position (longitude and latitude).

The user interface is shown in *figure 5*.

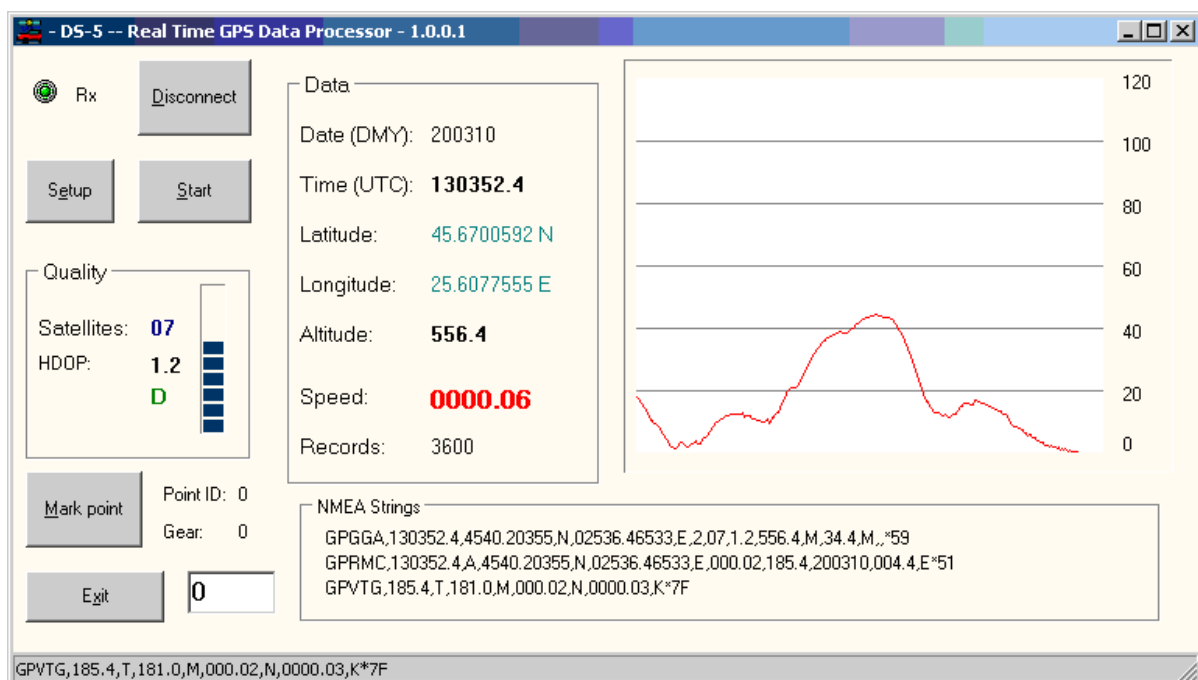

Fig. 5 – User interface of the DS-5 software

The main areas of the DS-5 user interface are:

- *Data* – displays the GPS data in real time;
- *Quality* – information about the signal quality: the number of satellites and *HDOP* (*Horizontal Dilution of Precision*); when differential signal is available in this area appear also the symbol „D”;
- *NMEA Strings* – the NMEA sequences received from the GPS device; these strings are displayed as an additional control of correctness of the acquired data;
- Graphical area (the white area in the right side of the screen) – in this area is displayed in real time the speed evolution, when the data recording is enabled;
- The marking area (bottom-left) – includes the „*Mark point*” button which is pressed to record the current position and the edit box „*GEAR*”, used to enter the current gear (numerical characters, between 0 and 6);
- The control area (upper-left) – this area contains the buttons used for configuration, connecting/disconnecting the GPS device and start/stop the recording; the buttons are big enough to be used with the touch screen of a tablet PC.

The NMEA sequences used are: \$GPRMC (position, velocity, time), \$GPGGA (3D position, accuracy information) and \$GPVTG (heading, real travel speed in knots and km/h). These sequences had a number of maximum 194 characters, which means a transfer rate of 2400 bauds for one record per second, or a rate of 19200 bauds for 5 records per second.

Data are recorded in text files. A row in the text file corresponds to a point on the track. An example row is:

```
25.2178867,45.5718372,800.5,Day 10 11 13:55:24.0 2009,0020.47,08
```

The fields in this row are: longitude, latitude, altitude, day of week, date and time, speed (km/h) and the number of available satellites.



Fig. 6 – Example of a DS-5 system installed on a vehicle (version with 2 receivers)

In *figure 6* is presented the system installed on a vehicle, with two GPS 18x-5Hz receivers and two instances of the computer program running on a tablet PC. The use of two GPS receivers on the same time is limited by the computer performances; the operating system should be able to use two serial interfaces simultaneously, without losing data.

APPLICATIONS

Typical applications for the DS-5 systems are the acceleration and braking tests and also the coast-down tests. Examples of acceleration and braking tests are shown in *figure 7* and *figure 8*, respectively.

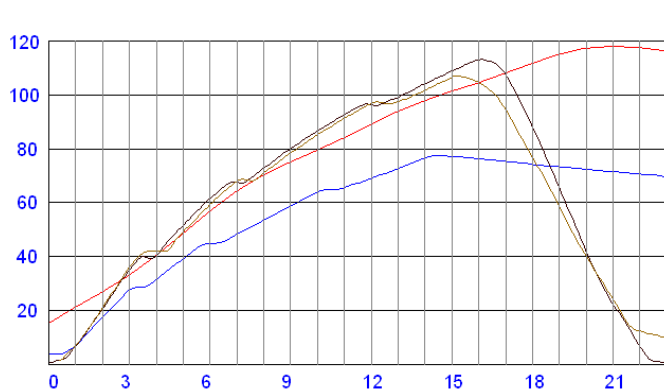

Fig. 7 – Example of acceleration tests recorded using different GPS devices

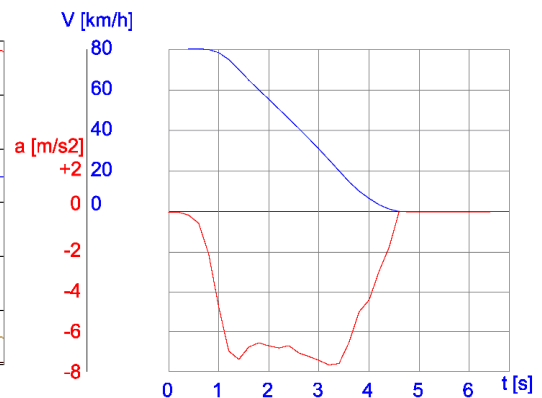

Fig. 8 - A braking test recorded with DS-5 – speed and acceleration

The curves in *figure 7* show the evolution of speed versus time during some acceleration tests recorded with different GPS devices. The black curve represents a record made with a Vbox system, a professional system used for vehicle dynamics data acquisition. The brown and the

blue curves represent records made with DS-5 system, and the red curve represents a record made with Garmin GPSmap 60CSx. The Vbox and DS-5 records show more details, including the gear changes. For this kind of tests, DS-5 gives results similar with the professional Vbox system, enough accurate but at a much lower cost.

The diagrams in *figure 8* represent a braking test. The blue curve is the speed versus time; the red curve is the acceleration. The braking time can be determined precisely and consequently the braking distance. The acceleration curve can give more details about the braking process.

CONCLUSIONS

DS-5 is a low cost data acquisition system, based on GPS technology. The performances are good enough for analysis of vehicle dynamics behaviour, but can be used also for collecting traffic data [1].

The DS-5 system has two components: the hardware equipment and the software application. The hardware is realized by putting together elements available on the commercial market: a high precision GPS sensor and a small size computer. The software component is an original application developed by authors.

The precision given by the GPS device (GPS 18x-5Hz) is as high as 7 decimals for longitude and latitude, 0.1 meter for altitude and 0.01 km/h for speed. The data sequences are transferred from the GPS device at a rate of 0.2 seconds; the time accuracy is given by satellites. The accuracy of recorded data is indicated by the number of satellites (8-10 satellites are available in good weather conditions) and the *HDOP* parameter. *HDOP* is usually less than 1.5 and can be even less than 1 meter when differential signal is available.

Although the positioning accuracy is increasing continuously, the errors remain an important problem, quite difficult to control, especially in reduced satellites visibility. However, a proper use in correlation with quality processing-algorithms permit to the GPS systems to provide a precision of speed and acceleration measurements at least as good as other measuring systems used in experimental research.

REFERENCES

- [1] Covaciu, D., Florea, D., Preda, I., Timar, J., *Using GPS Devices for Collecting Traffic Data*. SMAT2008 International Conference, Craiova, 2008.
- [2] Covaciu, D., *Solutions on the Study of Dynamic and In-Traffic Behaviour of Automotive Vehicles Through CAD/PLM and GPS Integration*. Ph.D. Thesis, Transilvania University of Braşov, 2010.
- [3] Preda, I., Ciolan, Gh., Covaciu, D. *Systems Based on GPS Devices Used for Vehicles Dynamic-Behaviour Study*. "Intelligent Transportation Systems ITS-Romania-2009" International Conference, Bucuresti, 2009.
- [4] Preda, I., Covaciu, D., Ciolan, Gh., *Vehicle Dynamics Study Based on GPS Devices*. NavMarEdu Conference, Constanţa, 2009.
- [5] Preda, I., Covaciu, D., Florea, D., Ciolan, Gh., *Study of In-Traffic Vehicle Behaviour, Based on GPS and Radar Devices*. ESFA2009 Conference, Bucureşti, 2009.
- [6] *** Garmin International, *Garmin Device Interface Specification*. <http://www.garmin.com>.
- [7] *** Garmin International, *Garmin Proprietary NMEA 0183 Sentence Technical Spec*. 2006.
- [8] *** Garmin International, *GPS 18x Technical Specifications, Revision B*. January 2008.